

SOKKIA

**SET5F
SET5FS
SET5W
SET5WS**

Electronic Total Station

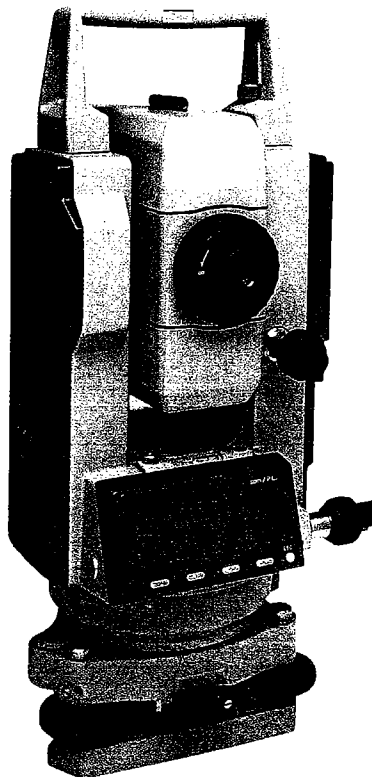

OPERATOR'S MANUAL



Ni-Cd

- **[English]** CONTAINS NICKEL-CADMIUM BATTERY. MUST BE RECYCLED OR DISPOSED OF PROPERLY.
- **[Deutsch]** MIT NiCd AKKU. EFORDERT RECYCLING ODER FACHGERECHTE ENTSORGUNG.
- **[Français]** CONTIENT UNE BATTERIE AU CADMIUM NICKEL. DOIT ÊTRE RECYCLÉE OU DONNÉE A UN ORGANISME DE RETRAITEMENT.
- **[Italiano]** CONTIENE NiCd BATTERIA. DEVE QUINDI ESSERE RICICLATA O ELIMINATA IN MODO APPROPRIATO.
- **[Nederlands]** BEVAT EEN NiCd BATTERIJ. DIENT GERECYCLEERD TE WORDEN OF OP EEN CORRECTE MANIER VERNIETIGD TE WORDEN.
- **[Español]** CONTIENE UNA NiCd BATERÍA. DEBE RECICLARSE O ELIMINARSE ADECUADAMENTE.
- **[Português]** CONTEM BATERIA DE NÍQUEL CÁDMIO. DEVERÁ SER RECICLADA OU DE CARTADA CONVENIENTEMENTE.
- **[Svensk]** INNEHÅLLER NiCd BATTERI. BÖR ÅTERVINNAS ELLER FÖRSTÖRAS PÅ ETT SÄKERT SÄTT.
- **[Suomi]** SISÄLTÄÄ NIKKELI-KADMIUM AKUN. HÄVITETTÄESSÄ KÄSITELTÄVÄ ONGELMAJÄTTEENÄ.
- **[Norsk]** NiCd BATTERIER MÅ RESIRKULERES ELLER KASTES PÅ EN FORSVARLIG MÅTE.
- **[Dansk]** INDEHOLDER NiCd BATTERI. SKAL GENVINDES ELLER KASSERES PÅ FORSVARLIG MÅDE.
- **[Ελληνικά]** ΠΕΡΙΕΧΕΙ ΜΠΑΤΑΡΙΑ ΝΙΚΕΛΙΟΥ-ΚΑΔΜΙΟΥ. ΠΡΕΠΕΙ ΝΑ ΑΝΑΚΥΚΛΩΝΕΤΑΙ Η ΝΑ ΚΑΤΑΣΤΡΕΦΕΤΑΙ ΜΕ ΤΟΝ ΚΑΤΑΛΛΗΛΟ ΤΡΟΠΟ.

For U.S.A. ATTENTION:

The product that you have purchased contains a rechargeable battery. The battery is recyclable. At the end of it's useful life, under various state and local laws, it may be illegal to dispose of this battery into the municipal waste stream. Check with your local solid waste officials for details in your area for recycling options or proper disposal. Use the standard battery charger.

Die Schweiz: Nach Gebrauch der Verkaufsstelle zurückgeben.
La Suisse: Après usage à rapporter au point de vente.
Swizzera: Ritornare la pila usate al negozio.

SET5F
SET5FS
SET5W
SET5WS

Electronic Total Station

OPERATOR'S MANUAL

- Thank you for selecting the SET5F/SET5FS/SET5W/SET5WS Electronic Total Station.
- Before using the instrument, please read this operator's manual.
- Verify that all equipment is included by referring to **"STANDARD EQUIPMENT"**, P168.
- The specifications and general appearance of the instrument may be altered at any time and may differ from those appearing in brochures and this manual.
- The picture on the cover and illustrations are of the SET5W.

► **IMPORTANT • For lithium battery**

A lithium battery is used to power the SET memory. This ensures “continuous memory” so that all data is safe. The lithium battery contains enough power to back up the memory for up to 10 years. If the lithium battery is completely discharged, all data will be cleared.

Backup battery low!

RAM cleared

Code file
checksum error
Code file deleted

Data checksum error!
delete all data ?
Yes No

If the lithium battery becomes low, an error message “Backup battery low!”, “RAM cleared” and “Code file checksum error Code file deleted” will be displayed at power-on. After that, “delete all data ?” is displayed. To download the data to a personal computer, press <No> and download the data in Data memory mode. If <Yes> is pressed, the data will be cleared. To replace the lithium battery, please contact your SOKKIA agent. When the battery is replaced, all data is cleared.

• **For rechargeable battery**

The battery has not been charged at the factory. Please charge the battery fully before using, referring to “22. POWER SUPPLIES”.

- **For Tribrach**

When the new SET is shipped, the tribrach clamp is fixed with a screw. Loosen it and leave it loose. If the SET is again shipped, fix the tribrach clamp with this screw to secure the tribrach to the instrument.

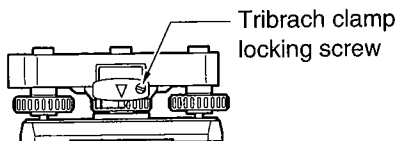

► **NOTE**

Service Mode Entry
Password = 000
[ESC] 3
[Up] [Down] [Left] [Right] Entry

- If the display appears as at left for some reason, please press **<ESC>**. The instrument returns to Basic mode.
(Usually this mode is not used.)

Table of Contents

ALWAYS FOLLOW PRECAUTIONS FOR SAFE OPERATION	viii
FEATURES	xii
EXPLANATION OF SOFTKEYS	xiii
HOW TO USE THIS MANUAL	xiv

Introduction

1. PRECAUTIONS	3
2. PARTS OF THE INSTRUMENT	4
3. DISPLAY SYMBOLS	6
4. KEY FUNCTIONS	7
5. MODE DIAGRAM	10

Preparation for measurement

6. MOUNTING THE BATTERY	13
7. SETTING UP THE INSTRUMENT	14
7.1 Centering	14
7.2 Levelling	16
8. POWER ON AND PREPARATION FOR MEASUREMENT	20
8.1 Power on and off	20
8.2 Indexing the vertical and horizontal circles	22
8.3 Focusing and target sighting	23
8.4 Display and reticle illumination	25
8.5 Setting the instrument options	26

Table of Contents

		<i>Measurement</i>
9.	ANGLE MEASUREMENT	33
9.1	Measure the horizontal angle between 2 points	34
9.2	Set Horizontal circle to a required value	35
9.3	Horizontal angle display selection	36
9.4	Horizontal angle repetition	37
9.5	Slope in %	39
10.	DISTANCE MEASUREMENT	40
10.1	Atmospheric correction	41
10.2	Return signal checking	44
10.3	Distance and angle measurement	45
10.4	Tracking measurement	47
10.5	Review of measured data	48
11.	COORDINATE MEASUREMENT	49
11.1	Instrument station coordinates setting	50
11.2	Target height and instrument height setting	52
11.3	Azimuth angle setting	53
11.4	3-Dimensional coordinate measurement	56
		<i>Advanced measurement functions</i>
12.	RESECTION MEASUREMENT	61
13.	MISSING LINE MEASUREMENT	66
13.1	Measuring the distance between 2 or more points	67
13.2	Changing the starting position	69
14.	SETTING-OUT MEASUREMENT	70
14.1	Distance setting-out measurement	71
14.2	Coordinates setting-out measurement	74
14.3	REM setting-out measurement	77
15.	OFFSET MEASUREMENT	78
15.1	Distance offset	79
15.2	Angle offset	81
16.	REM MEASUREMENT	83

Table of Contents

Using Data memory function

17. DATA MEMORY FUNCTION	89
17.1 Changing the instrument options	91
17.2 Job selecting	92
17.3 Instrument station data and Measured data recording ...	93
17.4 Instrument station data and Measured data reviewing / deleting / outputting	101
17.5 Feature code inputting / deleting / reviewing	104
17.6 Coordinate data inputting / deleting / reviewing	107

Troubleshooting

18. ERROR MESSAGES	113
19. CHECKS AND ADJUSTMENTS	116
19.1 Plate level	116
19.2 Circular level	118
19.3 Tilt sensor	119
19.4 Reticle	123
19.5 Optical plummet	128
19.6 Distance measurement check flow chart	130
19.7 Additive distance constant	131

Table of Contents

Measurement options selection

20. CHANGING INSTRUMENT PARAMETERS	135
21. CHANGING LOCATION OF FUNCTIONS FOR KEYS ...	144
21.1 Key function allocating	146
21.2 Registered location recalling	151
22. POWER SUPPLIES	153
23. REFLECTING PRISMS AND ACCESSORIES	156

Appendices

Appendix 1: Manually indexing the vertical circle by face left, face right measurements	161
Appendix 2: For distance measurement of the highest accuracy	162
Appendix 3: Earth-curvature and refraction correction .	164
Appendix 4: Standard accessories	165
Appendix 5: Optional accessories	166
STANDARD EQUIPMENT	168
MAINTENANCE	169
SPECIFICATIONS	170
ATMOSPHERIC CORRECTION CHART	174
REGULATIONS	175

ALWAYS FOLLOW PRECAUTIONS FOR SAFE OPERATION

For the safe use of the product and prevention of injury to operators and other persons as well as prevention of property damage, items which should be observed are indicated by an exclamation point within a triangle used with WARNING and CAUTION statements in this operator's manual.

The definitions of the indications are listed below. Be sure you understand them before reading the main text.

Definition of Indication



WARNING

Ignoring this indication and making an operation error could possibly result in death or serious injury to the operator



CAUTION

Ignoring this indication and making an operation error could possibly result in personal injury or property damage

Definition of Symbols



This symbol indicates items for which caution (hazard warnings inclusive) is urged.

Specific details are printed in or near the symbol.



This symbol indicates items which are prohibited.

Specific details are printed in or near the symbol.





This symbol indicates items which must always be performed.

Specific details are printed in or near the symbol.

General

WARNING

-  Never look at the sun through the telescope. Loss of eyesight could result.

-  Do not look at reflected sunlight from a prism or other reflecting object through the telescope. Loss of eyesight could result.

-  Direct viewing of the sun in sun observation will cause loss of eyesight. Use the solar filter (option) for sun observation.

-  Do not perform disassembly or rebuilding. Fire, electric shock or burns could result.

-  Do not use the main unit in areas exposed to high amounts of dust or ash, in areas where there is inadequate ventilation, or near combustible materials. An explosion could occur.

CAUTION

-  Secure handle to main unit with locking screws. Failure to properly secure the handle could result in the unit falling off while being carried, causing injury.

-  Tighten the adjustment tribrach clamp securely. Failure to properly secure the clamp could result in the tribrach falling off while being carried, causing injury.

-  Do not wield or throw the plumb bob. A person could be injured if struck.

-  Do not place the instrument in a case with a damaged catch, belt or handle. The case or instrument could be dropped and cause injury.

-  Do not use the carrying case as a footstool. The case is slippery and unstable so a person could slip and fall off of it.

Power Supply

WARNING

 Do not use voltage other than the specified power supply voltage. Fire or electrical shock could result.

 Use only the specified battery charger to recharge the batteries. Other chargers may be of different voltage rating or polarity causing sparking which could lead to fire or burns.

 Do not place articles such as clothing on the battery power charger while charging batteries. Sparks could be induced leading to fire.

 Do not use damaged power cords, plugs or loose outlets. Fire or electric shock could result.

Do not use batteries or the battery charger if wet. Resultant shorting could lead to fire or burns.
 Battery BDC25A meets IPX7 specification for waterproofing (immersion-proof). But shorting could occur if the terminals become wet.

 Do not use power cords other than those designated. Fire or electric shock could result.

 To prevent shorting of the battery in storage, apply insulating tape or the equivalent to the battery terminals. Otherwise shorting could occur resulting in fire or burns.

 Do not heat or throw batteries into fire. An explosion could occur resulting in injury.

CAUTION

 Do not connect or disconnect power supply plugs with wet hands. Electric shock could result.

 Do not touch liquid leaking from batteries. Harmful chemicals could cause burns or blisters.

Tripod

CAUTION

-  When mounting the instrument to the tripod, tighten the centering screw securely.
Failure to tighten the screw properly could result in the instrument falling off the tripod causing injury.

-  Securely tighten the leg fixing screws of the tripod on which the instrument is mounted.
Failure to tighten the screws could result in the tripod collapsing, causing injury.

-  Do not carry the tripod with the tripod shoes pointed at other persons.
A person could be injured if struck by the tripod shoes.

-  Keep hands and feet away from the tripod shoes when fixing the tripod in the ground.
A hand or foot stab wound could occur.

-  Tighten the leg fixing screws securely before carrying the tripod.
Failure to tighten the screws could lead to the tripod legs extending, causing injury.

FEATURES

WATERPROOF (SET5W/5WS)

- SET W/WS conforms to IP grade X7 specification for waterproofing (Immersion-proof) when the Connector caps are attached and the Battery BDC25A is mounted.

DUAL AXIS TILT SENSOR

- The vertical and horizontal angle value can be compensated.
- Vertical angle value only can be compensated.

SOFTKEYS

- All 4 function keys can be customized for your needs.

RESUME FUNCTION

- The previous mode at power off is memorized for about 1 week. When the SET is switched on, the previous mode is resumed.

AVERAGE IS CALCULATED

- The average of horizontal angle can be calculated and displayed in the repetition mode.
- The average of distance can be calculated and displayed in the average measurement mode.

ADVANCED MEASUREMENT

- Resection measurement
- Missing line measurement
- Setting-out measurement
- REM measurement

DATA CAN BE STORED IN AN INTERNAL MEMORY

- 3000 point data can be stored in an internal memory.

DATA OUTPUT

- The SET RS-232C compatible data output connector is provided for use with a data collector or an external device.

EXPLANATION OF SOFTKEYS

Softkeys

- The bottom line of the SET display lists 4 softkeys. A softkey is a software key; the definition of the key is shown in the bottom line of the display. Only the softkeys relevant to your current task appear. If you press the key under the displayed function, the function is performed. Up to 4 softkeys are available at a time.
For example, if you press the number one left key at the following display, the horizontal angle display is been set to 0.

			13
ZA	90° 00' 00"	- 30	
HAR	125° 56' 40"		■2
0SET	HOLD	Tilt	→P3

- By pressing the key under "→PX", the next page is displayed.
- "ESC" key is available in any mode. By pressing the "ESC" key, the mode is closed and the display returns to Basic mode. By pressing and holding, the power off and illumination functions are displayed.

Allocating functions for each key

- When SET left the factory, the location of the functions for each key were set to defaults. Any function can be allocated in any page of any mode. For a description of how to allocate functions, please refer to **"21. CHANGING LOCATIONS OF FUNCTIONS FOR KEYS"**.

HOW TO USE THIS MANUAL

- The SET allows you to change the location of functions for each key, so it is difficult to determine on which mode and page a function is located. Therefore, in this manual, the operations are mainly explained using the default location of the functions for keys.
- Typefaces are used in this manual as follows:

<Key> Indicates a keyboard key that causes an immediate action.
Examples: **<Sdist>**, **<↓>**, **<↑>**, **<Enter>** .

▶ **NOTE** Indicates additional information.

▶ **IMPORTANT** Indicates important information.

▶ **PRECAUTION** Indicates precaution information.

▶ **EXAMPLE** Indicates an operation example.

▶ **EXPLANATION** Indicates an explanation for a particular term or operation.

▶ **PROCEDURE** Indicates an operation procedure.

Introduction

1. PRECAUTIONS.....	3
2. PARTS OF THE INSTRUMENT	4
3. DISPLAY SYMBOLS	6
4. KEY FUNCTIONS	7
5. MODE DIAGRAM	10

1. PRECAUTIONS

- Never place the SET directly on the ground.
Avoid damaging the tripod head and centering screw with sand or dust.
- Do not aim the telescope at the sun.
Avoid damaging the LED of the EDM by using a solar filter when the telescope is pointed at the sun.
- Protect the SET with an umbrella against direct sunlight, rain and humidity (SET F/FS).
- Handle the SET with care. Avoid heavy shocks or vibration.
- When the operator leaves the SET, the vinyl cover should be placed on the instrument.
- Always switch the power off before removing the standard battery.
- Remove the standard battery from the SET before putting it in the carrying case.
When the SET is placed in the carrying case, follow the layout plan.
- Make sure that the inside of the carrying case and the instrument are dry before closing the case. If moisture is trapped inside the case, it may cause the instrument to rust.

PRECAUTION for SET 5W/5WS

- SET W/WS conforms to IP grade X7 specification for waterproofing (Immersion-proof) only when the Connector caps are attached and the Battery BDC25A is mounted. IPX7 does not guarantee the instrument if it is used or left in water.

Degree of water resistance

- Mount the Battery BDC25A and attach the Connector caps correctly. When remounting the battery or Connector caps, make sure water does not come in contact with the battery terminals and connectors. If moisture enters the inside of the instrument, it could damage the product.
- Make sure that the inside of the carrying case and the instrument are dry before closing the case. If moisture is trapped inside the case, it may cause the instrument to rust.
- The standard or optional accessories otherwise the Battery BDC25A do not meet IPX7 specifications.

2. PARTS OF THE INSTRUMENT

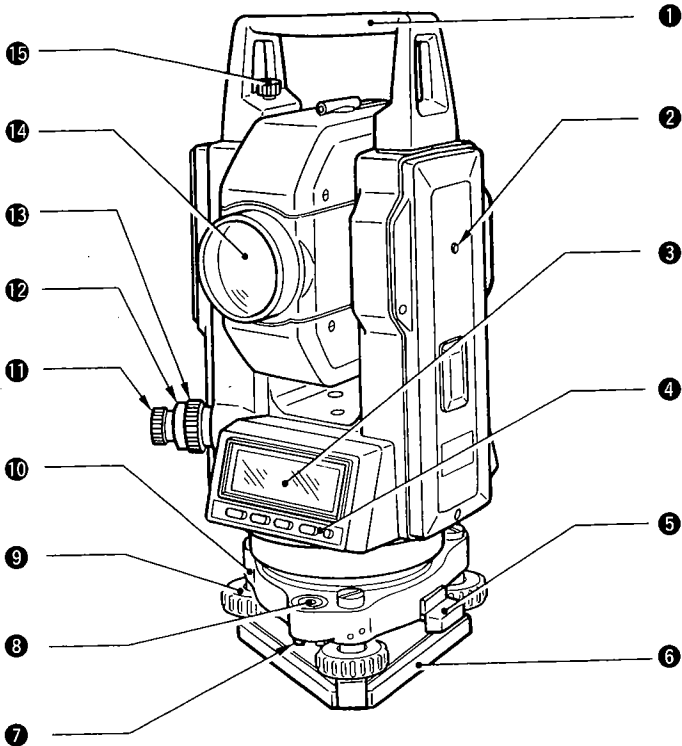

- | | |
|--------------------------|---|
| ① Handle | ⑦ Circular level adjusting screws |
| ② Instrument height mark | ⑧ Circular level |
| ③ Display | ⑨ Levelling foot screw |
| ④ Keyboard | ⑩ Tribrach |
| ⑤ Tribrach clamp | ⑪ Optical plummet eyepiece |
| ⑥ Base plate | ⑫ Optical plummet reticle adjusting cover |
| | ⑬ Optical plummet focussing ring |
| | ⑭ Objective lens |
| | ⑮ Handle securing screw |

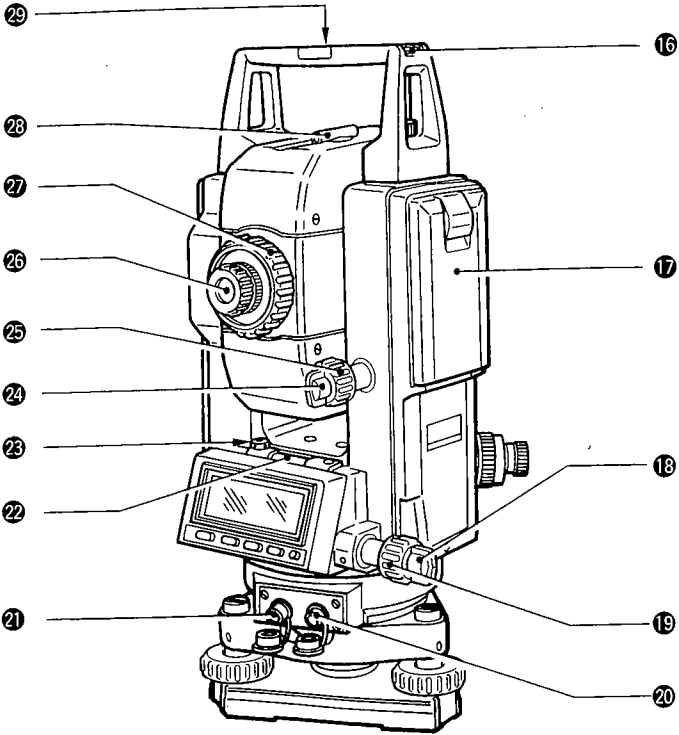

- | | | | |
|----|---------------------------------------|----|---|
| 16 | Tubular compass slot | 21 | External power source connector / Connector cap |
| 17 | Battery | 22 | Plate level |
| 18 | Horizontal clamp | 23 | Plate level adjusting screw |
| 19 | Horizontal fine motion screw | 24 | Vertical clamp |
| 20 | Data output connector / Connector cap | 25 | Vertical fine motion screw |
| | | 26 | Telescope eyepiece |
| | | 27 | Telescope focusing ring |
| | | 28 | Peep sight |
| | | 29 | Instrument center mark |

3. DISPLAY SYMBOLS

ZA	: Zenith angle (Z=0)	S	: Slope distance
VA	: Vertical angle (H=0) / Vertical angle (H=0±90°)		: Slope in % at Missing line measurement
	: Slope in %	H	: Horizontal distance
HAR	: Horizontal angle right	V	: Height difference
HAL	: Horizontal angle left	Ht.	: REM value
HAh	: Horizontal angle hold	_tk	: Tracking measurement data
HARp	: Horizontal angle repetition	_A	: Average measurement data
dHA	: Horizontal angle from setting-out data	Stn	: Instrument station coordinates
X	: Tilt angle in sighting direction	P	: Coordinate setting-out data
Y	: Tilt angle in horizontal axis direction	N	: N coordinate data
		E	: E coordinate data
⬆	: Tilt angle compensation on	Z	: Z coordinate data

<Remaining battery power>

(BDC25A, Temperature=25°C, EDM on)

■ 3 : 90 to 100%

■ 2 : 50 to 90%

■ 1 : 10 to 50%

■ 0 : 0 to 10%

4. KEY FUNCTIONS

- The key functions are listed below. To use the functions marked with “*”, allocate them to the softkeys by referring to “21. CHANGING LOCATION OF FUNCTIONS FOR KEYS”.

General

<ESC>: Transfer to Angle & Distance measurement mode

While holding <ESC>, <ILLUM>

: Display and reticle illumination ON/OFF

While holding <ESC>, <off>: Switch the power off

<THEO> : Transfer to Theodolite mode

<EDM> : Transfer to EDM mode

<S-O> : Transfer to S-O mode

<CONF> : Transfer to Setting mode

<↔PX> : Go to next page

<--->* : No function

<ILLUM> : Display and reticle illumination ON/OFF

<Enter> : Memorize the selected data

<Exit> : Exit from each mode

<CE> : Return to previous display

<EDIT> : Edit the data

<Input> : Change the displayed data

<Clear> : Set the data to 0

<off> : Switch the power off

<REC>* : Record Instrument station data and Measured data

<↑> : Move to previous option / Count up (*1)

<↓> : Move to next option / Count down (*1)

<↔> : Move to right option / Go to the next column (*1)

<1> : Select the number 1

<2> : Select the number 2

<3> : Select the number 3

For Angle measurement

- <0SET> : Set Horizontal angle to 0 / Index V circle
- <HOLD> : Hold H angle / Release H angle
- <Tilt> : Display the tilt angle
- <REP> : Transfer to Repetition mode
 - <BS> : Finish No.1 point sighting
 - <FS> : Finish No.2 point sighting
- <ZA/%> : Zenith angle / Slope in % (*²)
- <VA/%> : Vertical angle / Slope in % (*²)
- <R/L>* : Select Horizontal angle right / left

For Distance measurement

- <_dist> : Measure the distance
- <▲ SHV> : Select Distance mode
(S=Slope / H=Horizontal / V=Height)
- <PPM> : Go to ppm setting mode
- <M / TRK> : Repeat or single meas. / Tracking meas.
- <SIGNL> : Return signal check
- <f / m>* : Change meters / feet for 5 seconds
- <RCL>* : Review the measured data in the memory

For Coordinate measurement

- <Stn_P> : Input Instrument station coordinates
- <Ht.> : Input Target & Instrument height
- <BSang>* : Input Backsight station coordinates and set
Azimuth angle
- <COORD> : Measure 3-Dimensional coordinates
- <MEM> : Input / Delete / Review Coordinate data

For Advanced measurement

- <RESEC> : Go to Resection measurement mode
 - <Known> : Input Known point coordinates
 - <StnHt> : Input Instrument height
 - <Obs> : Start the observation of Known station
- <OFFS> : Start offset measurement

- <MLM> : Start Missing line measurement
 - <S / %> : Slope in % between 2 points
 - <Move> : Change the starting position
- <REM> : Start Remote elevation measurement
- <S-O_D> : Input Distance setting-out data
- <S-O_P> : Input Coordinates of point to be set out
- <SO_3D> : Start 3-dimension setting-out measurement
- <SO_Xd>* : Start Distance setting-out measurement
- <SO_HA>* : Start H angle setting-out measurement

► **NOTE** After performing these function, the display returns to the 1st page of the previous mode and the H angle and V angle are displayed.

(*1) : When <↑> , <↓> or <←→> is held down, scrolling of the selected function is performed.

(*2) : "ZA/%" is displayed when parameter "V angle format" is set to "Zenith 0".
"VA/%" is displayed when parameter "V angle format" is set to "Horizontal 0" or "Horizontal ±90°".

5. MODE DIAGRAM

Basic mode

EDM THEO S-O CONF

<EDM> EDM mode

Sdist ▲SHV THEO →P2

PPM M/TRK SIGNAL →P3

REM MLM OFFS →P1

- Distance measurement
- Atmospheric correction
- Tracking measurement
- Return signal checking
- REM measurement
- Offset measurement

<THEO> Theodolite mode

Sdist EDM ILLUM →P2

OSET HOLD Tilt →P3

REP ZA/% R/L →P1

- Horizontal angle 0 set
- Horizontal angle hold
- Tilt angle display
- Repetition measurement
- Slope in %
- Horizontal angle right/left

<S-O> Setting-out mode

SO_3D S-O_P S-O_D →P2

Stn_P Ht. COORD →P3

MEM RESEC ▲SHV →P1

- Coordinate measurement
- Setting-out measurement
- Resection measurement

<CONF> Setting mode

1. Configuration

2. Tilt correction

3. Key select

■1■ ■2■ ■3■ Exit

- Parameter setting
- Tilt sensor adjusting
- Key function allocating

• Press ESC key to go to Basic mode from every mode.

• This location of the functions for keys is the default setting. To use other functions, allocate them by referring to "21. CHANGING LOCATION OF FUNCTIONS FOR KEYS".

Preparation for measurement

6.	MOUNTING THE BATTERY	13
7.	SETTING UP THE INSTRUMENT	14
	7.1 Centering	14
	7.2 Levelling	16
8.	POWER ON AND PREPARATION FOR MEASUREMENT	20
	8.1 Power on and off	20
	8.2 Indexing the vertical and horizontal circles	22
	8.3 Focusing and target sighting	23
	8.4 Display and reticle illumination	25
	8.5 Setting the Instrument options	26
	▶ EXPLANATION Automatic tilt angle compensation	27
	▶ EXPLANATION Horizontal angle back-up	27
	▶ EXPLANATION Resume function	28
	▶ EXPLANATION Parallax	28
	▶ EXPLANATION Power-saving cut-off	28
	▶ EXPLANATION Levelling using the tilt angle display	28



6. MOUNTING THE BATTERY

- Charge the battery fully before measurement.

► **NOTE** Switch off the power before replacing the battery.

► PROCEDURE Mounting the battery

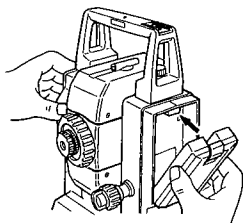
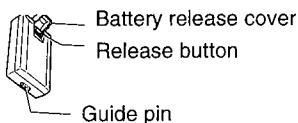

1. Close the battery release cover.
2. Match the battery guide with the hole in the instrument battery recess.
3. Press the top of the battery until a click is heard.

Removing the battery

① Open the battery release cover

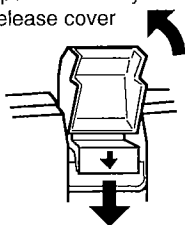

② Press the release button downward

1. Open the battery release cover.
2. Press the release button downward.
3. Remove the battery.

- If the power is to be switched on immediately after replacing the battery, please refer to "8.1 Power on and off".

7. SETTING UP THE INSTRUMENT

- Mount the battery in the instrument before performing this operation, because the instrument will tilt slightly if the battery is mounted after levelling.

7.1 Centering

► PROCEDURE

Set up the tripod

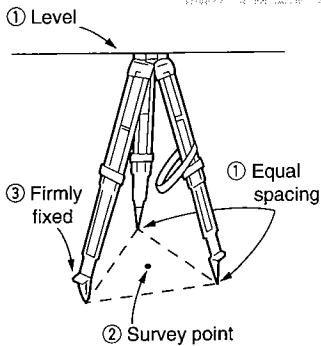

1. Make sure the legs are spaced at equal intervals and the head is approximately level.
2. Set the tripod so that the head is positioned over the surveying point.
3. Make sure the tripod shoes are firmly fixed in the ground.

Install the instrument

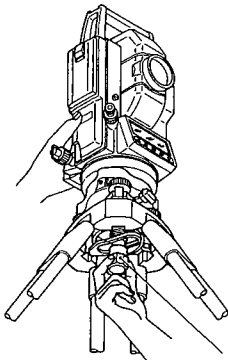

Centering screw

4. Place the instrument on the tripod head.
5. Supporting it with one hand, tighten the centering screw on the bottom of the unit to make sure it is secured to the tripod.

Focus on the surveying point

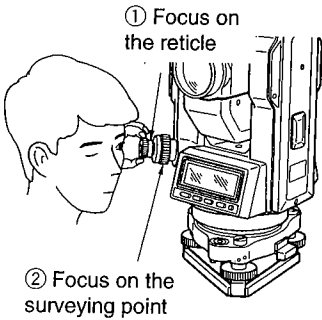

6. Looking through the optical plummet eyepiece ①, turn the optical plummet eyepiece to focus on the reticle.
7. Turn the optical plummet focusing ring ⑬ to focus on the surveying point.

7.2 Levelling

► PROCEDURE

Center the surveying point in the reticle



1. Adjust the levelling foot screws ⑨ to center the surveying point in the optical plummet reticle.

Center the bubble in the circular level

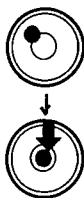
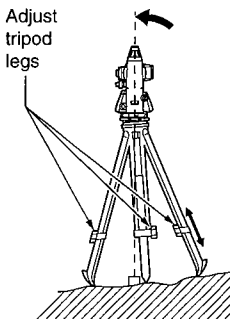

2. Observe the off-center direction of the bubble in the circular level ⑧, and shorten the nearest tripod leg, or extend the leg farthest from the direction to center the bubble.
3. One more tripod leg must be adjusted to center the bubble.

Center the bubble in the plate level

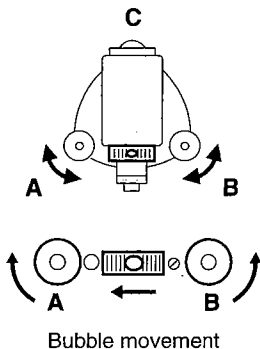

4. Loosen the horizontal clamp ⑱ to turn the upper part of the instrument until the plate level ⑳ is parallel to a line between levelling foot screws A and B.
5. Center the air bubble, using levelling foot screws A and B.
 - The bubble moves towards a clockwise rotated levelling foot screw.

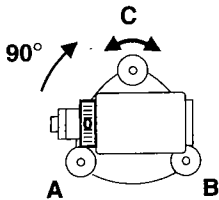
Turn 90° and center the bubble

6. Turn the upper part of the instrument through 90°. The plate level is now perpendicular to a line between levelling foot screws A and B.
7. Center the air bubble, using levelling foot screw C.

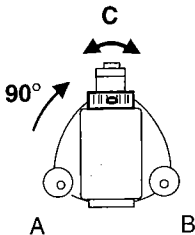
Turn another 90° and check bubble position

8. Turn the upper part of the instrument a further 90° and check to see if the bubble is in the center of the plate level.

If the bubble is off-center, perform the following:

- ① Adjust levelling foot screws A and B in equal and opposite directions to remove half of the bubble displacement.
- ② Turn the upper part a further 90°, and use levelling foot screw C to remove half of the displacement in this direction.

Or try the adjustment described in “19.1 Plate level”.

Check to see if bubble is in same position in any direction

9. Turn the instrument and check to see if the air bubble is in the same position for any position of the upper part. If it is not, repeat the levelling procedure.

Center the SET over the Surveying point SET5F/5W

10. Loosen the centering screw slightly.
11. Looking through the optical plummet eyepiece, slide the instrument over the tripod head until the surveying point is exactly centered in the reticle.
12. Retighten the centering screw securely.
13. Check again to make sure the bubble in the plate level is centered. If not, repeat the procedures starting from step 4.

**Center the SET over the Surveying point
SET5FS/5WS**

10. Turn the tribrach shifting clamp counterclockwise.
Shifting tribrach can be adjusted up to $\pm 8\text{mm}$.

11. Looking through the optical plummet eyepiece, adjust the instrument position on the tribrach to center the surveying point.

12. Tighten the shifting clamp to fix the instrument in the center position.

8. POWER ON AND PREPARATION FOR MEASUREMENT

- The following preparations are required for measurement.

- 8.1 Power on and off
- 8.2 Indexing the vertical and horizontal circles
- 8.3 Focusing and target sighting
- 8.4 Display and reticle illumination
- 8.5 Setting the instrument options

8.1 Power on and off

► PROCEDURE Power on and off

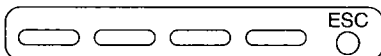

```

ZA  0 SET
HAR 0 SET  
  
```

```

Tilt out of range
X-  >  ⊥  +
Y-   ⊥  <+  
  
```

X: Tilt angle in the sighting direction

Y: Tilt angle in the horizontal axis direction

Press any one of the 5 keys

When the power is switched on, a self-check is run to make sure the instrument is operating normally. After that, the display indicates that the instrument is ready for vertical and horizontal circle indexing.

- If this error message is displayed, the instrument tilt sensor is indicating that the instrument is off-level. Relevel the instrument once again until  is displayed. To switch the power off, while holding <ESC>, press <off>.

* "Tilt angle compensation" ► EXPLANATION Automatic tilt angle compensation, on P.27

- **NOTE** Instrument parameter "Tilt correction" (refer to chapter 20) Parameter "Tilt correction" can be used to switch off and on the automatic tilt angle compensation; for example, it should be switched off if the display is unsteady due to vibration or strong wind.

RAM Cleared

ZA V 1
HAR 0 SET

ZA 0 SET
HAR 0° 00' 00"

Battery is low !

- When all data has been cleared from the memory, the display appears as at left. After that the instrument is ready for vertical and horizontal circle indexing.
- When "V1" is displayed for the vertical angle, please refer to "Appendix1: Manually indexing the vertical circle".
- When the parameter "H indexing" is set to "Manual", "0" is displayed for the horizontal angle.
- If the battery is at the "low" level, the message "Battery is low !" will be displayed. Switch the power off and charge the battery.

- **NOTE** Instrument parameter "V indexing" (refer to chapter 20) Parameter "V indexing" can change the vertical indexing method. Options are indexed by transitting the telescope or indexing by face left, face right sightings.

- **NOTE** Instrument parameter "H indexing" (refer to chapter 20) Parameter "H indexing" can be used to change the horizontal circle indexing method. Options are indexed by rotating the upper part or indexing and zero setting at power-on.

8.2 Indexing the vertical and horizontal circles

► PROCEDURE Vertical circle indexing

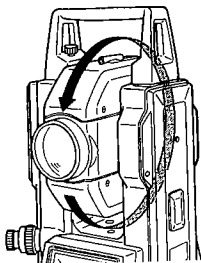

1. Loosen the vertical clamp 24 and transit the telescope completely.
(Indexing occurs when the objective lens crosses the horizontal plane in face left.)
An audio tone sounds, and the vertical angle (ZA) is displayed.

Horizontal circle indexing

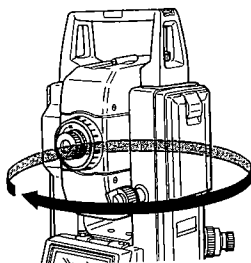

2. Loosen the horizontal clamp 18 and rotate the upper part of the instrument completely.
An audio tone sounds, and the horizontal angle (HAR) is displayed.
- Vertical indexing and horizontal indexing have been completed.

- **NOTE** Each time the instrument is switched on, the vertical and horizontal indexes must be redetermined.
If the parameter “Resume function” is set to “on”, the screen previous to power off is displayed. To change the parameter to “off”, refer to chapter 20.

8.3 Focusing and target sighting

► PROCEDURE Focus on the reticle

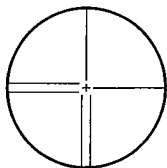

1. Look through the telescope eyepiece 26 at a bright and featureless background.
2. Turn the eyepiece clockwise, then counterclockwise little by little until just before the reticle image becomes focused.
 - Using these procedures, frequent reticle refocusing is not necessary, since your eye is focused at infinity.

Sight the target

3. Loosen the vertical 24 and horizontal 18 clamps, and use the peep sight 28 to bring the target into the field of view. Tighten both clamps.

Focus on the target

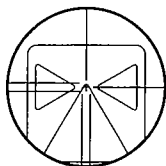

<Target center>

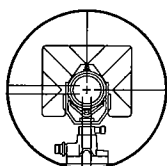

<Prism center>

4. Turn the telescope focusing ring 27 to focus on the target.
5. Turn the vertical 25 and horizontal 19 fine motion screws to align the target with the reticle.

The last adjustment of each fine motion screw should be in the clockwise direction.

Readjust the focus until there is no parallax

6. Readjust the focus with the focusing ring ② until there is no parallax between the target image and the reticle.

► **NOTE** Observe to the same point of the reticle when the telescope face is changed.

• There is no parallax" ► **EXPLANATION Parallax**, on P.28.

8.4 Display and reticle illumination

► PROCEDURE Display and reticle illumination on/off

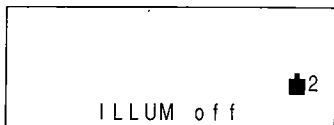

- While holding <ESC>, press <ILLUM> to turn the display and reticle illumination on and off.

Holding <ESC>, press <ILLUM>

- **NOTE** Instrument parameter “Auto power off” (refer to chapter 20) Parameter “Auto power off” can be used to switch ON/OFF the 30-second illumination automatic cut-off facility.
- **NOTE** Instrument parameter “Backlight timeout” (refer to chapter 20) Parameter “Backlight timeout” can be used to change the brightness of the reticle illumination.
- **NOTE** To display ILLUM function
The key function allocation allows <ILLUM> to be displayed in any page of any mode. See “21. CHANGING LOCATION OF FUNCTION FOR KEYS”.

8.5 Setting the Instrument options

- Confirm that these parameters are set according to your measurement needs. Especially be sure to set the parameters of “EDM measurement” and “Prism constant” to your requirements.
- To confirm or change the parameter options, please refer to “**20. CHANGING INSTRUMENT PARAMETERS**”.

Parameter	Options
EDM measurement (Distance measurement mode)	1. Fine and average (Repeat* / Average of 2 to 9 meas.) 2. Fine and single 3. Coarse and single
Prism constant correction value	-30mm* (-99 to 0mm, in 1mm steps)
Distance unit	1. meters* 2. feet
C+R correction	1. No correction* 2. Yes
Meas. mode default (Distance mode)	1. Slope distance* 2. Horizontal distance 3. Height difference
Angle unit	1. degree* 2. gon 3. mil
Vertical angle format	1. Zenith angle (Zenith 0)* 2. Vertical angle (Horizontal 0) 3. Vertical angle (Horizontal $\pm 90^\circ$)
Tilt correction	1. Horizontal and Vertical angle Yes* 2. Vertical angle Yes 3. No correction
Coordinate format	1. N, E, Z* 2. E, N, Z
Angle resolution	1. 1" / 0.2mgon / 0.005mil* 2. 5" / 1mgon / 0.02mil
Temperature and Pressure unit	1. °C, hPa* 2. °C, mmHg 3. °F, hPa / °F, mmHg / °F, inchHg

*: Factory setting

► EXPLANATION Automatic tilt angle compensation

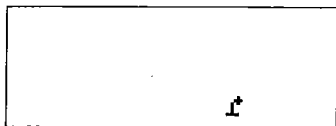

- When the compensation symbol is shown on the display, the vertical and horizontal angles are automatically compensated for small tilt errors using the 2-axis tilt sensor.
- Read the compensated angles after the displayed angle values become steady.
- The formula used for calculation of the compensation value applied to the horizontal angle uses the tilt and vertical angles as follows:
Compensated horizontal angle
= Measured horizontal angle + Tilt in angle Y / \tan (vertical angle).
Therefore, when the SET is not perfectly levelled, changing the vertical angle by rotating the telescope will cause the displayed horizontal angle value to change. (The displayed horizontal angle value will not change during telescope rotation when the instrument is correctly levelled.)
- When the measured vertical angles are within $\pm 1^\circ$ of the zenith or nadir, tilt compensation is not applied to the horizontal angle. In this situation, the displayed horizontal angle value flashes to show that the tilt compensation is not being applied.

► EXPLANATION Horizontal angle back-up

- The parameter "H circle indexing" default setting allows for the memorization of the previous horizontal 0 position at power-off for about 1 week. The horizontal left or right angle display selection is also memorized. When next switching on the SET and indexing the horizontal circle again, the horizontal angle is recovered at the previously-memorized 0 position. This feature is useful when the battery voltage becomes low during measurement or after automatic power-off has occurred.

► EXPLANATION Resume function

- “Resume function” means to return to or begin again after interruption. It means that the previous mode is recovered after switching on the SET and indexing the vertical and horizontal circles.
- The resume function does not work after more than 1 week (memory back-up period). In that case or when the resume function “no” is selected, the SET returns to Theodolite mode after switching on and indexing the vertical and horizontal circles.

► EXPLANATION Parallax

- This is the relative displacement of the target image with respect to the reticle when the observer's head is moved slightly before the eyepiece.
Parallax will introduce reading errors and must be removed before observations are taken. Parallax can be removed by refocusing the reticle.

► EXPLANATION Power-saving cut-off

- The SET switches off automatically 30 minutes after the last operation.

► NOTE Instrument parameter “Auto power cut-off” (refer to chapter 20) Parameter “Auto power cut-off” can be changed so that the SET will not switch off automatically after 30 minutes.

► EXPLANATION Levelling using the tilt angle display

- For levelling, the tilt angle X and Y values can be displayed for use as a 2-axis (X,Y) tilt sensor. The measurement range is $\pm 3^\circ$.

► PROCEDURE

Set the telescope parallel to a line between levelling foot screws A and B

1. Turn the upper part of the instrument until the telescope is parallel to a line between levelling foot screws A and B and tighten the horizontal clamp **18**.

Display the tilt angle

<Tilt>

HAR	0° 00' 00"	
Tilt X	0° 01' 20"	
Y	0° 00' 40"	■2

2. In 2nd page of THEO mode, press <Tilt>.

The X and Y tilt angles are displayed.

Set both tilt angles to 0

3. Set both tilt angles to 0° by turning the levelling screws A and B for the X direction and C for the Y direction.
4. To exit from the tilt angle display, press <Exit> to return to the previous mode or press <ESC> to go to Basic mode.

► **NOTE** "Tilt out of range" indicates that the tilt angle exceeds the $\pm 3'$ measurement range.

Tilt out of range			
X_	>	┃	+
Y_		┃	<+
			■2



9. ANGLE MEASUREMENT	33
9.1 Measure the horizontal angle between 2 points	34
9.2 Set Horizontal circle to a required value	35
9.3 Horizontal angle display selection	36
9.4 Horizontal angle repetition	37
9.5 Slope in %	39
10. DISTANCE MEASUREMENT	40
10.1 Atmospheric correction	41
10.2 Return signal checking	44
10.3 Distance and angle measurement	45
10.4 Tracking measurement	47
10.5 Review of measured data	48
11. COORDINATE MEASUREMENT	49
11.1 Instrument station coordinates setting	50
11.2 Target height and instrument height setting	52
11.3 Azimuth angle setting	53
11.4 3-Dimensional coordinate measurement	56



9. ANGLE MEASUREMENT

- The following functions are available for angle measurement.

- 9.1 Measure the horizontal angle between 2 points (Horizontal angle 0)
- 9.2 Set Horizontal circle to a required value (Horizontal angle hold)
- 9.3 Horizontal angle display selection (Right / left)
- 9.4 Horizontal angle repetition
- 9.5 Slope in %

► **NOTE** Check before Angle measurement:

1. The SET is set up correctly over the surveying point.
2. The remaining battery power is adequate.
3. The V and H circles have been indexed.
4. The instrument parameters have been set.

► **NOTE** Vertical and Horizontal angle recording
The key function allocation allows <REC> to be displayed in any page of any mode. By using this function after angle measurement, SET can store the data into the memory. See "21. CHANGING LOCATION OF FUNCTIONS FOR KEYS" and "17. DATA MEMORY FUNCTION".

9.1 Measure the horizontal angle between 2 points (H angle 0)

- To measure the angle between 2 points, the horizontal circle can be set to 0 at any direction.

► PROCEDURE Horizontal angle 0 set

2nd page of THEO mode

			0
ZA	112° 21' 20"	- 30	
HAR	350° 38' 10"	▲2	
OSET HOLD Tilt			→P3

In 2nd page of THEO mode

<OSET>

			0
ZA	112° 21' 20"	- 30	
HAR	0° 00' 00"	▲2	

Press <OSET> to set the horizontal angle to zero.

► EXAMPLE Measure the horizontal angle between 2 points

First target

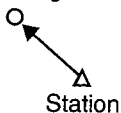

- Using horizontal clamp 18 and fine motion screw 19, sight the first target as at left.

<OSET>

			0
ZA	112° 21' 20"	- 30	
HAR	0° 00' 00"	▲2	

- In THEO mode, press <OSET>.

The horizontal angle display has been set to "0°" as at left.

Second target



- Sight the second target.

The displayed horizontal angle is the angle between the 2 points.

9.2 Set Horizontal circle to a required value

- You can set the horizontal circle of the target direction to a required value.

PROCEDURE Horizontal angle hold / release

2nd page of THEO mode

ZA	112° 21' 20"	- 30	0
HAR	350° 38' 10"	■2	
0SET HOLD Tilt →P3			

<HOLD>

In 2nd page of THEO mode

- Press <HOLD> to set the required horizontal angle value.
- Press <HOLD> again to cancel the entered horizontal angle.

2nd page of THEO mode

ZA	112° 21' 20"	- 30	0
HAh	350° 38' 10"	■2	
0SET HOLD Tilt →P3			

<HOLD>

EXAMPLE Set Horizontal circle to a required value

ZA	80° 21' 20"	- 30	0
HAR	60° 00' 20"	■2	

- In THEO mode, use the horizontal clamp **18** and fine motion screw **19** to turn the theodolite until a required value is shown on the display.

<HOLD>

ZA	80° 21' 20"	- 30	0
HAh	60° 00' 20"	■2	

- Press <HOLD> to set the horizontal angle.

The display on the left shows the horizontal angle for the target set to a required value.

The value entered becomes the horizontal angle
Sight the reference target, <HOLD>

- Sight the reference target and press <HOLD> again to release the setting.

9.3 Horizontal angle display selection (Right / left)

► PROCEDURE

Horizontal angle right / left

3rd page of THEO mode

			0
ZA	112° 21' 20"	-30	
HAR	90° 00' 00"		2
REP	ZA / %	R / L	→ P1

<R/L>

3rd page of THEO mode

			0
ZA	112° 21' 20"	-30	
HAL	270° 00' 00"		2
REP	ZA / %	R / L	→ P1

<R/L>

In 3rd page of THEO mode

- Press <R/L> to select horizontal angle left.
- Press <R/L> to select horizontal angle right.

9.4 Horizontal angle repetition

- For higher accuracy horizontal angle measurement, the average of the horizontal angle can be measured by repetition. The SET can calculate and display the average of the horizontal angle.

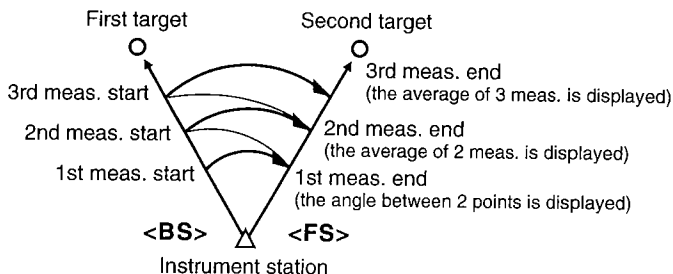

► PROCEDURE Horizontal angle repetition

3rd page of THEO mode

```

0
ZA 112° 21' 20" -30
HAR 350° 38' 10" 2
REP ZA/% R/L →P1
  
```

<REP>

H angle repetition mode

```

HARp 0° 00' 00"
HARp base point
2
CE BS FS Exit
  
```

<BS>

```

HAR 0° 00' 00"
Reps. = 00
2
CE BS FS Exit
  
```

<FS>

In 3rd page of THEO mode

- Sight the first target.
- Press <REP> to select horizontal angle repetition mode.
- Press <BS> to start 1st measurement.
- Sight the second target.
- Press <FS> to display the angle between two points.
(The angle of the 2nd target is held.)

HARp	140° 00' 00"
Reps.	= 01
Ave.	140° 00' 00"  2
CE	BS FS Exit

<BS>

HAR	0° 00' 00"
Reps.	= 01
Ave.	140° 00' 00"  2
CE	BS FS Exit

<FS>

6. Sight the first target again.

7. Press **<BS>** to release horizontal angle hold and begin second measurement.

8. Sight the second target again.

9. Press **<FS>** to display the average of the 2 measurements at the 3rd line.
(The angle of the 2nd target is held.)

- To continue the measurement, repeat steps 6 to 9.

10. Press **<EXIT>** to end horizontal angle repetition mode.

- In Repetition mode, the displayed horizontal angle is not corrected by the tilt sensor.
- When the data output is requested by an external device in H angle repetition mode, H angle from 0°, which is determined before selecting H angle repetition mode, is output. The average of measurements is not output.
- Number of measurements: Up to 10 times.
- Repetition display range: $\pm 3599^\circ 59' 59''$
- To previous measurement: **<CE>**
- Exit from the mode: **<Exit>**

9.5 Slope in %

- The SET can display the slope in %.

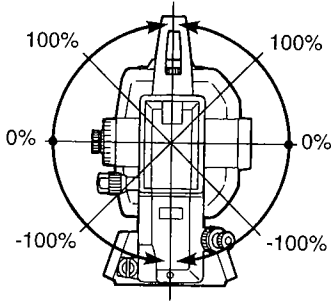

► PROCEDURE Slope in %

3rd page of THEO mode

```
ZA  90° 13' 50"
HAR  0° 00' 00"  ▀2
REP  ZA/%  R/L  →P1
```

<ZA/%>

In 3rd page of THEO mode

- Press <ZA/%> to display Slope in %.

3rd page of THEO mode

```
VA  -0.402 %
HAR  0° 00' 00"  ▀2
REP  ZA/%  R/L  →P1
```

<ZA/%>

- Press <ZA/%> to display Vertical angle.

- Display range: Less than $\pm 1000\%$
- <ZA/%> is displayed when parameter "V angle format" is set to "Zenith 0°". <ZA/%> is displayed when parameter "V angle format" is set to "Horizontal 0°" or "Horizontal $\pm 90^\circ$ ".

10. DISTANCE MEASUREMENT

- The following preparations are required for Distance measurement.
 - 10.1 Atmospheric correction
 - 10.2 Return signal checking
- The distance is measured according to the parameter “EDM measurement” (the measurement mode) which you selected in “8.5 Setting the Instrument options”.
Refer to chapter 20 to change the measurement mode.
- When the data output is requested by an external device in Average measurement mode, the data is output the selected number of times.

► **NOTE** Slope distance recording
The key function allocation allows <REC> to be displayed in any page of any mode. By using this function after distance measurement, the SET can store the data into the memory. See “21. CHANGING LOCATION OF FUNCTIONS FOR KEYS” and “17. DATA MEMORY FUNCTION”.

► **NOTE** Change feet / meter
The key function allocation allows <f/m> to be displayed in any page of any mode. Press <f/m> to change the distance unit for 5 seconds. See “21. CHANGING LOCATION OF FUNCTIONS FOR KEYS”.

10.1 Atmospheric correction

- The atmospheric correction is necessary for accurate distance measurement, because the velocity of light in air is affected by the temperature and atmospheric pressure. The SET is designed so that the correction factor is 0 ppm for a temperature of 15°C (59°F) and an atmospheric pressure of 1013hPa (29.9 inchHg).

► **NOTE** To obtain the average refractive index of the air throughout the measured light path, you should use the average atmospheric pressure and temperature. Take care when calculating the correction factor in mountainous terrain. Refer to “**Appendix 2**”.

- By inputting the temperature and pressure values, the correction value is calculated and set into the memory. The formula used is as follows:

$$pm = 278.96 - \frac{0.2904 \times P \text{ (hPa)}}{1 + 0.003661 \times T \text{ (°C)}}$$

If the atmospheric correction is not required, set the ppm value to 0.

- To input ppm value, read the correction factor from the table in “**ATMOSPHERIC CORRECTION CHART**”.

► EXAMPLE

Reading the correction factor from the table

- Temperature = 25°C
 Pressure = 1000hPa
 → The correction value is +13ppm

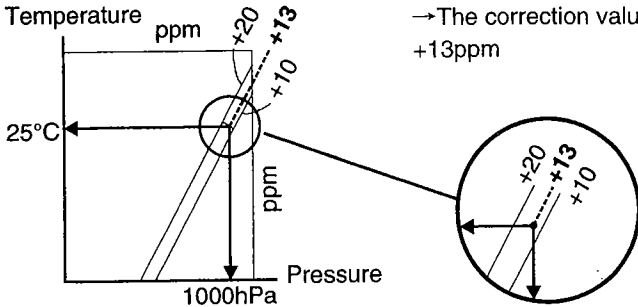

► PROCEDURE

ppm setting mode

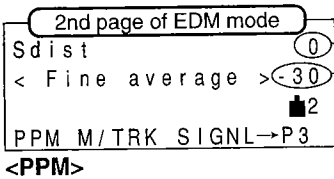

In 2nd page of EDM mode

- Atmospheric correction value
- Prism constant correction value

1. Press <PPM> to go to ppm setting mode.

- Press <1> to cancel set up of ppm input and return to EDM mode.

2. Press <2> to set up temperature and pressure input.

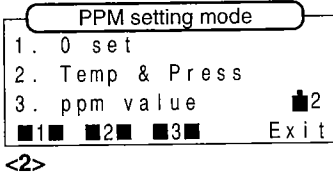

Input Temperature & Pressure

T. 15 °C

P. 1013 hPa

■2

■↑ ■↓ ■→ Enter

<↑> <↓>, <→>
<Enter>

- Input Temperature using <↑> (count up) <↓> (count down), and press <Enter>. (To move the column, press <→>.)

- Input Pressure.

- Press <Enter> to set Pressure (EDM mode).

- Temperature input range: -30 to 60°C • Least input: 1°C
- Pressure input range: 500 to 1400hPa • Least input: 1hPa
- Exit from ppm mode: <ESC> (To Basic mode)

Input ppm value

ppm= +01.3

■2

■↑ ■↓ ■→ Enter

<Enter>

- Press <3> to set up correction value input.

- Input the ppm value using <↑> (count up) <↓> (count down), and press <Enter>. (To move the column, press <→>.)

- ppm input range: -499 to 499ppm
- ppm Least input: 1ppm
- Exit from ppm mode: <ESC> (To Basic mode)

10.2 Return signal checking

- Especially for long distances, it is useful to check that the returned signal is adequate for measurement.

► PROCEDURE Return signal checking

2nd page of EDM mode

```
Sdist 0
< Fine average > -30
      ■2
PPM M/TRK SIGNAL →P3
```

<SIGNL>

Return signal checking mode

```
Sdist 0
< Fine average > -30
Return signal■■■■■ ■2
Sdist Exit
```

<Exit> or <_dist>

In 2nd page of EDM mode

1. Sight the center of the target with the telescope.
2. Press <SIGNL> to go to Return signal checking mode.

"_____": No return signal

"■■■■", "■■■■■", "■■■■■■",

_____ : Adequate for measurement

"■■■■": Return signal is too strong

2. Press <Exit> to quit Checking mode or press <_dist> to start the distance measurement.

- When "_____ " is displayed, sight the reflecting prism center again.
- When "■■■■■" is displayed and if this display persists, please contact our agent.
- When the light intensity coming back from the reflecting prism is very high (short distance) the mark "■■■■" is displayed, even for a slight mis-sighting. Therefore make sure that the target center is sighted correctly.

10.3 Distance and angle measurement

► **NOTE** Check before Distance measurement:

1. The SET is set up correctly over the surveying point.
2. The remaining battery power is adequate.
3. The V and H circles have been indexed.
4. The instrument parameters have been set.
5. The atmospheric correction is set.
6. The center of the target is correctly sighted.

► PROCEDURE S/H/V selection and Distance meas.

1st page of EDM mode

```
Sdist          13
< Fine average > -30
                █2
Sdist ▲SHV THEO →P2
```

<▲SHV>

In 1st page of EDM mode

1. Press <▲SHV> to select slope distance, Horizontal distance and Height difference.

```
Sdist          13
< Fine average > -30
                █2
Sdist ▲SHV THEO →P2
```

<_dist>

2. Press <dist> to start Distance measurement.
The measured distance, vertical angle and horizontal angle are displayed.

```
S      123.456 m      13
ZA    112° 21' 20"   -30
HAR   350° 38' 10"   █2
STOP
```

<STOP>

3. Press <STOP> to stop the measurement.

- If the single measurement or the average measurement mode has been selected, the measurement stops automatically.
- Stop the measurement: <STOP>
- The distance and angle measured most recently are stored in memory. Pressing <▲SHV> allows you to display Horizontal distance or Height difference.

► EXAMPLE

- Measure the horizontal distance 3 times in the fine measurement mode, and display its average

- Confirm the following:
 1. The parameter "EDM measurement" is set to "fine and average" and "3 times".
 2. In EDM mode, "Horizontal distance" is selected by pressing <▲SHV>, or in THEO mode, <Hdist> is displayed.

► PROCEDURE

Sight the target and start the measurement

<Hdist>

		13
Hdist	-30	
		2
STOP		

H-1	1234.568 m	13
H-2	1234.567 m	13
H-3	1234.566 m	13
ZA	80° 21' 20"	-30
HAR	60° 00' 20"	2

H-A	1234.5670m	13
ZA	80° 21' 20"	-30
HAR	60° 00' 20"	2

1. Sight the target.
2. In the 1st page of EDM mode, press <Hdist>.

"Hdist" flashes and the distance measurement is started.

After that, the horizontal distance, the vertical angle and the horizontal angle are displayed. The distance is measured 3 times.

After 0.4 second, the average of 3 measurements is displayed in 0.1mm steps and the measurement is stopped.

H-A: Average of H distance

- In the case of the average measurement, the last-displayed horizontal distance is calculated by using the average of the selected number of measurements of the slope distance and last-measured angle. The height difference is calculated by the same way.

10.4 Tracking measurement

- Tracking measurement is used for fast, non-high accuracy distance measurement. Tracking is useful when the distance to a moving reflecting prism is measured, for example, when setting-out points.
- If Tracking is selected, the distance is measured independently of parameter "EDM measurement" setting.

► PROCEDURE Tracking measurement

2nd page of EDM mode

```
Sdist 13
< Fine average > -30
      ■2
PPM M/TRK SIGNAL →P3
```

In 2nd page of EDM mode

- Press **<M/TRK>** to select Tracking measurement.
- Sight the reflecting prism.
- Press **<_dist>** to start the distance measurement.

<M/TRK>

1st page of EDM mode

```
Sdist 13
< Tracking > -30
      ■2
Sdist SHV THEO →P2
```

The measured distance and vertical and horizontal angles are displayed.

<_dist>

```
Stk 123.45 m 13
ZA 112° 21' 20" -30
HAR 350° 38' 10" ■2
STOP
```

- Press **<STOP>** to stop the measurement.

<STOP>

- Press **<M/TRK>** again to return to previous mode.

10.5 Review of measured data

- The distance and angle measured most recently are stored in the memory until the power is switched off.

The stored slope distance, horizontal distance and height difference can be displayed in Recall mode as follows.

► PROCEDURE Data recall

3rd page of EDM mode

```
Sdist      13
< Fine average > -30
                ■2
REM  MLM  OFFS  →P1
```

<RCL>

```
S-A      14.5678m   13
ZA       80° 21' 20"  -30
HAR      60° 00' 20"   ■2
Sdist  ▲SHV THEO →P2
```

In 3rd page of EDM mode

1. Press <RCL> to go to Recall mode.

The stored data measured most recently is displayed.

2. Press <ESC> to end Recall mode and go back to Basic mode.

11. COORDINATE MEASUREMENT

- The SET calculates the 3-Dimensional coordinates of the prism position by inputting the instrument height, the target height and the instrument station coordinates and by measuring the slope distance, the horizontal angle and the vertical angle of the prism position.

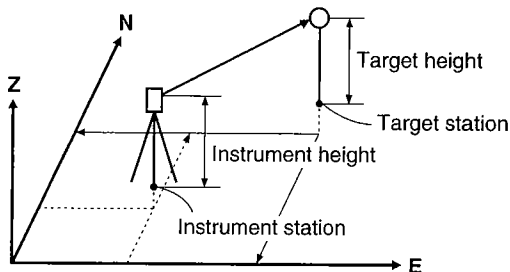

- The following preparations are required for Coordinate measurement.
 - 11.1 Instrument station coordinates setting
 - 11.2 Target height and Instrument height setting
 - 11.3 Azimuth angle setting
- The distance is measured according to the parameter "EDM measurement" (the measurement mode) which you selected in "8.5 Setting the Instrument options". Refer to chapter 20 to change the measurement mode.

► **NOTE** Measured Coordinate recording

The key function allocation allows <REC> to be displayed on any page of any mode. By using this function after coordinate measurement, the SET can store the data into the memory. See "21. CHANGING LOCATION OF FUNCTIONS FOR KEYS" and "17. DATA MEMORY FUNCTION".

► **NOTE** Coordinate data inputting

By using <MEM>, the SET can store coordinate data into the memory. The stored data can be used as instrument station coordinates and backsight station coordinates.

11.1 Instrument station coordinates setting

- The coordinates of the instrument station can be input into the SET.

► PROCEDURE Instrument station coordinates setting

2nd page of S-O mode

```

  1 3
S-O / COORDS   -30
  2
Stn_P Ht. COORD →P3
  
```

<Stn_P>

```

Stn N      0.000
  E        0.000
  Z        0.000
Input Read Clear Exit
  
```

<Input>

```

Stn N  000000.000
  E  +000000.000
  Z  +000000.000
  ↑  ↓  →  Enter
  
```

<↑> <↓>, <→>

<Enter>

<Read>

```

Coord.      12345678
Stn_p       12345679
Coord.      12345680
  ↑  ↓  →  Enter Exit
  
```

In 2nd page of S-O mode

1. Press <Stn_P> for Instrument station coordinates setting mode.
2. Press <input> to set up input of instrument Station coordinates.
 - Press <Read> to read Instrument station coordinates from memory and select the point number using <↑> and <↓>, and press <Enter>. Then press <Yes> to set the displayed coordinates.
3. Input N coordinate using <↑> (count up) <↓> (count down), and press <Enter>. (To move the column, press <→>.)
4. Input E and Z coordinates in the same way.

- Input range: -999999.999 to 999999.999m
 - Least input: 0.001m
 - Retain the displayed value: **<Exit>**
 - Set the value to 0: **<Clear>**
 - Exit from the mode: **<ESC>** (To Basic mode)
-
- If the Instrument station coordinate is not known, the "Resection measurement" can be used to determine the instrument station coordinates. See chapter 12.

11.2 Target height and Instrument height setting

- In preparation for Coordinate measurement, the instrument height and target height should be input to the SET before the measurement.

Target height: the height difference between the surveying point and the center of the target

Instrument height: the height difference between the surveying point and the instrument station height mark

- The heights of the instrument and target must be measured manually beforehand, using a measuring tape, etc.

► PROCEDURE

Target height & Instr. height setting

2nd page of S-O mode

```

13
S-O / COORDS -30
                ■2
Stn_P Ht. COORD →P3
  
```

<Ht.>

```

Tgt Ht.      0.000
InstrHt.     0.000

Input --- Clear Exit
  
```

<Input>

```

Tgt Ht.  (+)0000.000
InstrHt. +0000.000

■↑■ ■↓■ ■→■ Enter
  
```

<↑> <↓>, <→>

<Enter>

In 2nd page of S-O mode

- Press <Ht.> for Target & Instrument height setting mode.
- Press <Input> to set up Target & Instr. height settings.
- Input Target height using <↑> (count up) <↓> (count down), and press <Enter>. (To move the column, press <→>.)
- Input Instr. height and set it in the same way.

- Input range: -9999.999 to 9999.999m • Least input: 0.001m
- Retain the displayed value: **<Exit>** • Set the value to 0: **<Clear>**
- Exit from the mode: **<ESC>** (To Basic mode)

11.3 Azimuth angle setting

- With the SET, the azimuth angle of the backsight can be automatically calculated from the input instrument station and backsight station coordinates.
- Sight the backsight station and set the azimuth angle of it. This means the horizontal angle is set to zero in the N direction.
- To use the azimuth angle setting function, allocate **<BSang>** beforehand, referring to "21 CHANGING LOCATION OF FUNCTIONS FOR KEYS".

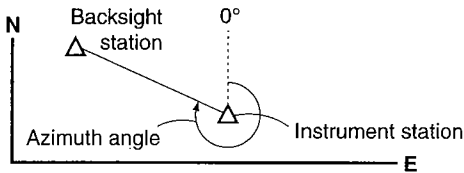

► PROCEDURE Azimuth angle setting

<BSang>

```

Azimuth angle setting mode
13
BS azimuth angle -30
  2
BS_P Stn_P Obs Exit
  
```

In any page of any mode

1. Press **<BSang>** for Azimuth angle setting mode.

<BS_P>

BS	N	0.000
	E	0.000
Input Read Clear Exit		

<Input>

BS	N	000000.000
	E	+000000.000
■↑■ ■↓■ ■→■ Enter		

<↑> <↓>, <→>

<Enter>

<Read>

Coord.	12345678
Coord.	12345679
Coord.	12345680
■↑■ ■↓■ Enter Exit	

- Press **<Stn_P>** if setting Instrument station coordinates. See "11.1 Instrument station coordinates setting".
- 2. Press **<BS_P>** for setting Backsight station coordinates
- 3. Press **<Input>** to set up coordinates input.
- Press **<Read>** to read Instrument station coordinates from memory and select the point number using <↑> and <↓>, and press **<Enter>**. Then press **<Yes>** to set the displayed coordinates.
- 4. Input N coordinate using <↑> (count up) <↓> (count down), and press **<Enter>**. (To move the column, press <→>.)
- 5. Input E coordinate in the same way.

- Input range: -9999.999 to 9999.999m
- Least input: 0.001m
- To previous display: **<Exit>**
- Set the value to 0: **<Clear>**
- Exit from the mode: **<ESC>** (To Basic mode)

Azimuth angle setting mode	
	13
BS azimuth angle	-30
	2
Stn_P	Obs
	Exit

<Obs>

 Backsight station

 Instrument station

	13
BS observation	-30
	2
Yes	Exit

<Yes>

1st page of THEO mode	
	13
ZA	81° 59' 20" -30
HAR	45° 00' 00" 2

6. Press <Obs> to start the observation.

7. Sight Backsight station.

8. Press <Yes> to calculate Azimuth angle.

HAR: Azimuth angle of Backsight station

11.4 3-Dimensional coordinate measurement

- The coordinates of the target are calculated using the following formulas and the results are then displayed. It is first necessary to input the instrument station coordinates, the instrument and target heights and to set the azimuth angle.

$$N1 = N_0 + S \times \sin \theta z \times \cos \theta h$$

$$E1 = E_0 + S \times \sin \theta z \times \sin \theta h$$

$$Z1 = Z_0 + Mh + S \times \cos \theta z - Ph$$

N_0 : Instr. station N coordinate S : Slope distance Mh : Instr. height

E_0 : Instr. station E coordinate θz : Zenith angle Ph : Target height

Z_0 : Instr. station Z coordinate θh : Azimuth angle

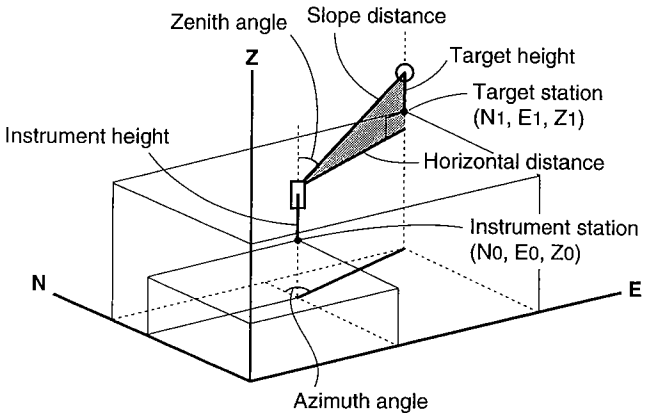

► **NOTE** Check before Coordinate measurement:

1. The SET is set up correctly over the surveying point.
2. The remaining battery power is adequate.
3. The V and H circles have been indexed.
4. The instrument parameters have been set.
5. The atmospheric correction is set.
6. 11.1 to 11.3 have been performed.

► PROCEDURE **Coordinate measurement**



1. Sight the target.

In 2nd page of S-O mode

2nd page of S-O mode			
			13
S-O / COORDS			-30
			▣2
Stn P	Ht.	COORD	→P3

2. Press **<COORD>** to start Coordinate measurement.

<COORD>

			13
Coordinate			-30
			▣2

3. Press **<STOP>** to stop the measurement.

N	1234.564		13
E	1234.564		-30
Z	1.234		▣2
STOP			

<STOP>

- To measure the next target point, check the target height.



Advanced measurement functions

12. RESECTION MEASUREMENT	61
13. MISSING LINE MEASUREMENT	66
13.1 Measuring the distance between 2 or more points	67
13.2 Changing the starting position	69
14. SETTING-OUT MEASUREMENT	70
14.1 Distance setting-out measurement	71
14.2 Coordinates setting-out measurement	74
14.3 REM setting-out measurement	77
15. OFFSET MEASUREMENT	78
15.1 Distance offset	79
15.2 Angle offset	81
16. REM MEASUREMENT	83



12. RESECTION MEASUREMENT

- The “Resection measurement” is used to determine the instrument station coordinates by observing 2 or more known points.

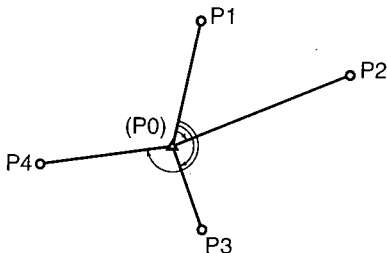

- The SET can calculate the instrument station coordinates by observing 2 to 5 known points. To calculate the instrument station coordinates:
 - ① When the distance can be measured, 2 known points are required.
 - ② When the distance of even 1 point cannot be measured, at least 3 points are required.
- The more known points that are observed and the more distances that are measured, the higher the precision of the calculation.
- The calculated station point coordinates can be stored in the memory of the SET. The stored data can be used as known station coordinates. To store the calculated coordinates, see “**17.3 Instrument station data and Measured data recording**”.

► PROCEDURE **Resection measurement**

3rd page of S-O mode

S - O / COORDS	13
	- 30
	▀2
MEM RESEC ▲SHV	→P2

<RESEC>

P1	N	0.000	
	E	0.000	
	Z	0.000	
Input	Read	Clear	OK

<Input>

P1	N	+000000.000	
	E	+000000.000	
	Z	+000000.000	
▀↑▀	▀↓▀	▀→▀	Enter

<↑><↓><→><Enter>

<Read>

Stn-P	00000002	
Stn-P	00000003	
Stn-P	00000004	
▀↓▀	Enter	Exit

<↑><↓><Enter>

P1	N	3.000
	E	2.000
	Z	1.000
Yes	No	

<Yes>

In 3rd page of S-O mode

1. Press <RESEC> to go to Resection measurement point.

2. Input or read from memory the first known point coordinates.

- To input the first known point,
 - ① Press <Input>
 - ② Input coordinates using <↑> (count up) and <↓> (count down), and press <Enter>. (To move the column, press <→>.)

- To read coordinates from memory
 - ① Press <Read>.
 - ② Display the required point number using <↑> and <↓>, and press <Enter> to select the point.
 - ③ Press <Yes> to set the displayed coordinates.

3. Input or read coordinates of other known points.

<Obs>

P1	N	3.000	
Obs:	E	2.000	
	Z	1.000	
Sdist	Angle	TgtHt	Exit

<Sdist> or <Angle>

<STOP>

S	14.567 m	13	
ZA	80° 21' 20"	-30	
HAR	60° 00' 20"	■2	
Yes	No		

<Yes>

S	14.567 m	13	
ZA	80° 21' 20"	-30	
HAR	60° 00' 20"	■2	
Yes	No	CAL	

<CAL>

Stn	N	1234.000	
	E	1234.000	
	Z	1.234	
Yes	No	Rec	BS

4. After inputting all known points (up to 5 points), press **<Obs>** and start the observations.

- Press **<TgtHt>** to input the target height.

5. Sight the first target. When you measure the distance, press **<Sdist>** and **<STOP>**. When you do not measure the distance, press **<Angle>**.

6. Press **<Yes>**.

7. Observe known points other than the last point. When the number of sighted known points is sufficient to calculate the instrument station, **<CAL>** is displayed.

8. Sight the last known point and press **<CAL>**. "Busy" is displayed and the SET starts to calculate the instrument station. When the calculation is finished, the result is displayed.

- When the SET cannot find the solution of the calculation, “no solution” is displayed. You can select whether to re-observe from the first point (start point) or only the last point.
 - When a calculation error occurs, “Calculation error” is displayed and the screen returns to allow you to input the known point. Input known point again.
 - When the number of observed points is not sufficient for calculation, “Too few point” is displayed. Add (input) and observe more points.
9. Press **<Yes>** to confirm the result.
Press **<Rec>** to record the station point.
Press **<BS>** to set the azimuth angle of the known point to the last known point.
- For details about **<REC>**, see “17.3 Instrument station data and measured data recording”.

► EXPLANATION Situation to be selected and avoided

- The instrument station coordinates may not be calculated correctly when the instrument station and more than 3 known stations are on a single circle.

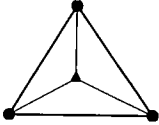

- Situation to be selected

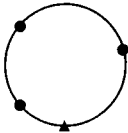

- Situation to be avoided
- When the known station may be on a single circle:

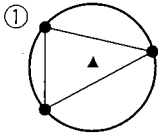

- Move the instrument station as close as possible to the center of the triangle.

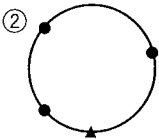

- Observe one more known point which is not on the circle.

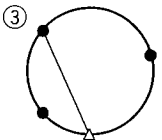

- Measure the distance of at least 1 known point.

- When the included angle between the known points is too narrow or the distances between the instrument station and the known stations are too long, the SET may not be able to find the solution of the calculation.

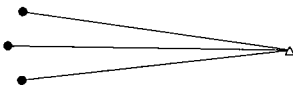

13. MISSING LINE MEASUREMENT

- The missing line measurement is used to measure the slope, horizontal distances and height difference between the starting position (P1) and any other points without moving the instrument itself.

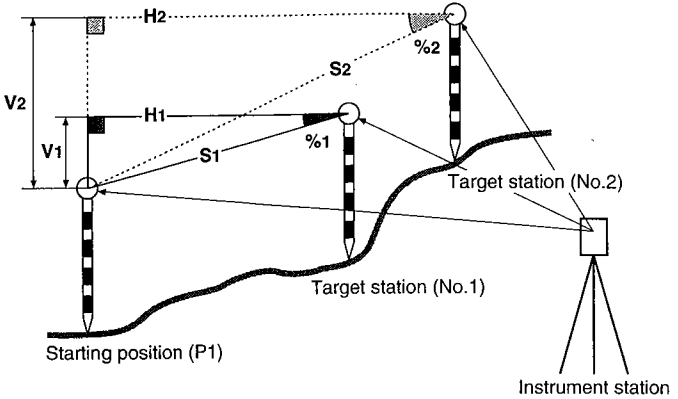

- To measure the distances between the surveying points, set the reflecting prism on a fixed height object, such as a pole.
- The distance is measured according to the parameter “EDM measurement” (the measurement mode) which you selected in “**8.5 Setting the instrument options**”. Refer to chapter 20 to change the measurement mode.

13.1 Measuring the distance between 2 or more points

- The SET can measure the distances to many points consecutively.

► PROCEDURE Missing line measurement

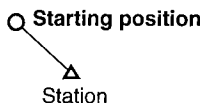

- Sight the reflecting prism on the starting position.

1st page of EDM mode

Sdist	13
< Fine average >	-30
Sdist	▲SHV THEO →P2
<_dist>	

In 1st page of EDM mode

- Select <Sdist>, <Hdist> or <Vdist> to start Distance measurement.
(Stop the measurement)

S	14.567 m	13
ZA	80° 21' 20"	-30
HAR	60° 00' 20"	■2

- Sight the reflecting prism on Target Station No.1.

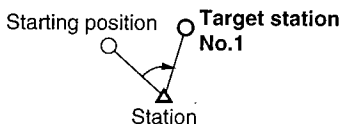

Sdist	▲SHV THEO →P2
<→PX><→PX>	

- Press <→PX><→PX> to go to 3rd page.

REM	MLM	RCL	→P1
<MLM>			

- Press <MLM> to start Missing line measurement.

Missing line	13
	-30
	■2

S	14.567 m	13
H	20.757 m	-30
V	1.012 m	■2
STOP	S/%	Exit

<STOP>

S	14.567 m	13
H	20.757 m	-30
V	1.012 m	■2

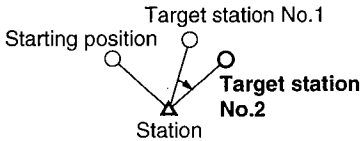

MLM	Move S/%	Exit
-----	----------	------

<MLM>

6. Press <STOP> to stop the measurement.

Slope distance, Horizontal distance and Height difference between 2 points is displayed.

S: Slope distance
H: Horizontal distance
V: Height difference

7. Sight the reflecting prism on Target station No.2.

8. Press <MLM> to start Missing line measurement.

- Repeat the above procedures to start the next missing line measurement
- Exit from the missing line mode: <Exit> (To EDM mode)

- The SET can display the slope between 2 points in %.

► PROCEDURE **Slope in % between 2 points**

S	14.567 m	13
H	20.757 m	-30
V	1.012 m	■2
MLM	Move S/%	Exit

<S/%>

S	48.755 %	13
H	20.757 m	-30
V	1.012 m	■2

When missing line measurement has finished, press <S/%> to display Slope in %.

- Press <S/%> again to display the slope distance
- Display range: Less than ±1000% (Horizontal = 0%)

13.2 Changing the starting position

- The last measured target station can be changed to become the next starting position.

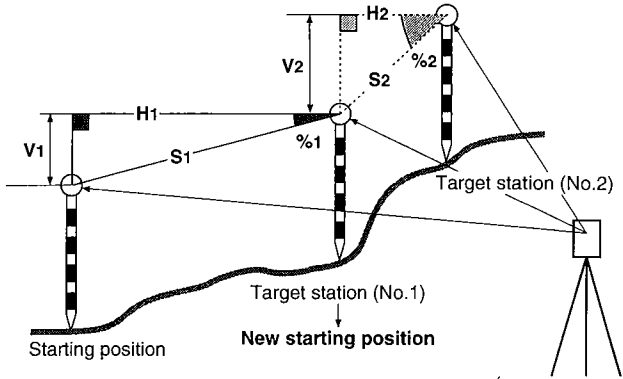

► PROCEDURE

Changing the starting position

S	14.567 m	13
H	20.757 m	-30
V	1.012 m	■2
MLM Move S/% Exit		

<Move>

Missing line	13
point replaced	-30
	■2

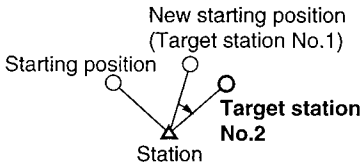

MLM	Move	S/%	Exit
-----	------	-----	------

<MLM>

When missing line measurement has finished,

1. Press <Move> to change the starting position.

The data for the last target station is set as the data for the new starting position.

2. Sight each target station and press <MLM> to continue. Missing line measurement from the new starting position to the next target stations.

14. SETTING-OUT MEASUREMENT

- The Setting-out measurement is used to set out the required point.

The difference between the previously input data to the instrument (the setting-out data) and the measured value can be displayed by measuring the horizontal angle, horizontal distance (<SO_Hd>), coordinates (<Coord>), or height (<SO_Ht>) of the sighted point.

Setting out mode (<S-O>)

<3D_SO> ———— 	<SO_Xd>	Distance setting-out
	<Coord>	Coordinate setting-out
	<SO_Ht>	REM Setting-out

Displayed value

= Difference between measured value and setting-out data

- The distance is measured according to the parameter “EDM measurement” (the measurement mode) and Tracking measurement mode selection.

14.1 Distance setting-out measurement

- This measurement is used to set out the point from a reference direction and a certain distance away from the instrument station.

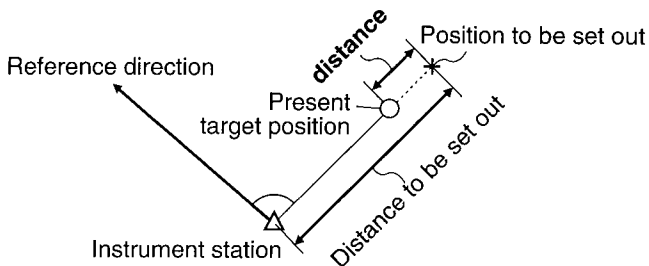

► PROCEDURE Distance setting-out measurement

Reference direction

1. Sight the reference direction.

Instrument station

2. In 2nd page of THEO mode, press **<OSET>** to set Horizontal angle to 0.

2nd page of THEO mode

			13
ZA	81° 59' 20"	-30	
HAR	45° 00' 00"		2
OSET	HOLD	Tilt	→P3

<OSET>

			13
ZA	81° 59' 20"	-30	
HAR	0° 00' 00"		2
Sdist	EDM	ILLUM	→P2

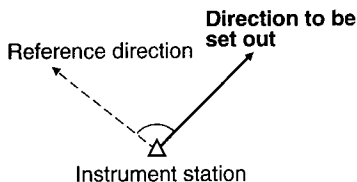

<ESC>

Basic mode			
Press function	13		
keys to select	-30		
operation		2	
EDM	THEO	S-O	CONF

<S-O>

1st page of S-O mode			
			13
S-O / COORDS			-30
			2
SO_3D	S-O_P	S-O_D	→P2

<S-O_D>

Distance S-O data setting mode	
S-O distance	0.000
Input	--- Clear Exit

<Input>

S-O distance	+0000.000		
▲	▼	→	Enter

<↑><↓> and <→>

<Enter>

1st page of S-O mode			
			3
ZA	90° 21' 40"		-30
HAR	45° 53' 20"		2
SO_3D	S-O_P	S-O_D	→P2

3. Turn the theodolite until a required angle is shown on the display.

4. Press <ESC> to go to Basic mode.

5. Press <S-O> go to S-O mode.

6. Press <S-O_D> for Distance S-O data setting mode.

7. Input Distance S-O data. Press <Input> and input horizontal distance S-O data using <↑> (count up) and <↓> (count down). (<→> is to go to next column.) Then press <Enter>.

8. Set the reflecting prism on the sighting line and sight it correctly.

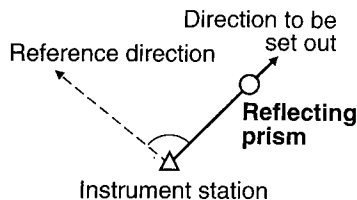

<SO_3D>

<SO_Hd>

H	14.567m	13
dHA	80° 21' 20"	-30
HAR	60° 00' 20"	■2

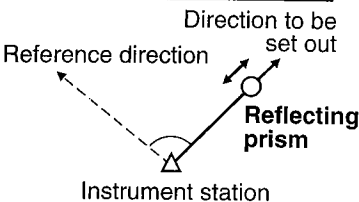

H	0.000m	13
ZA	80° 21' 20"	-30
HAR	60° 00' 20"	■2
STOP		

<STOP>

- If necessary, press <▲SHV> to select H distance mode or press <M/TRK> to select the Tracking measurement mode.
9. Press <SO_3D> and <SO_Hd> (horizontal distance setting-out) to start Distance S-O measurement.

The difference between the setting-out data and the measured distance is displayed at the 1st line.

10. Move the reflecting prism towards or away from the instrument until H distance becomes 0m to determine the point.
 - data: Move away from Instr.
 - + data: Move towards Instr.

11. Press <STOP> to stop the measurement.
(1st page of S-O mode)

- It is possible to set out a slope distance, horizontal distance, height difference value after setting the required value.
- When the Repeat measurement or the Tracking measurement is selected, sighting the moving reflecting prism again changes the distance without key operation.
- Retain the displayed value: <Exit> (To 1st page of S-O mode)
- Set the value to 0: <Clear>
- Input range: -9999.999 to 9999.999m • Least input: 0.001m

14.2 Coordinates setting-out measurement

- This measurement is used to set out the point of a coordinate away from the reference point (the instrument station).
- After inputting the coordinates for the point to be set out, the SET calculates the setting-out horizontal angle, horizontal distance and the height, and stores the values in the memory. By using **<SO_3D>**, the required coordinate location can be set out.

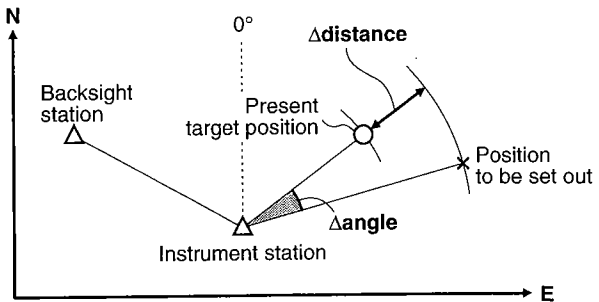

► PROCEDURE

Set the backsight station

1. Set the coordinates and azimuth angle of the backsight station
Refer to "11.3 Azimuth angle setting".

Input instrument station and setting-out point

S-O / COORD
Stn_P Ht. COORD →P3
<Stn_P>

2. In 2nd page of S-O mode, press **<Stn_P>** and input or read the instrument station coordinates.

- In 1st page of S-O mode, press **<S-O_P>** and input the coordinates of the point to be set out.
- In 2nd page of S-O mode, press **<Ht.>** and input the target height and the instrument height.

Perform the H angle S-O measurement

<SO_3D>

Direction to be set out

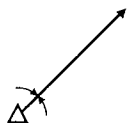

Instrument station

- Press **<SO_3D>** for the S-O measurement and use the horizontal clamp and fine motion screw to turn the theodolite until the "dHA" value becomes $0^{\circ}00'00''$.

		13
dHA	$0^{\circ} 00' 00''$	- 30
HAR	$87^{\circ} 34' 20''$	

Perform the H distance setting-out measurement

- Set the reflecting prism on the sighting line and sight it correctly.
- Press **<SO_Hd>** to start distance setting-out measurement.

<SO_Hd>

H	2.567m	13
dHA	$80^{\circ} 21' 20''$	- 30
HAR	$60^{\circ} 00' 20''$	
STOP		

- If necessary, press **<▲SHV>** to select H distance mode before pressing **<SO_3D>**.

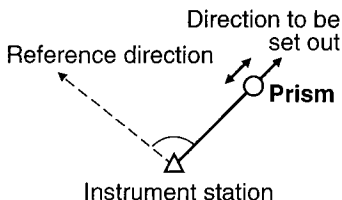

H	0.000m	13
dHA	80° 21' 20"	-30
HAR	60° 00' 20"	■2
STOP		

<STOP>

The difference between the setting-out data and the measured distance is displayed at the first line.

8. Move the reflecting prism towards or away from the instrument until the horizontal distance becomes 0m to determine the distance of the point.
 - data: Move away from the instrument
 - + data: Move towards the instrument
9. Press <STOP> to stop the measurement.

Perform height setting-out measurement

<Coord>

N	0.000	13
E	0.000	-30
Z	3.284	■2
STOP		

N	0.000	13
E	0.000	-30
Z	0.000	■2
STOP		

<STOP>

10. Press <Coord> to start height setting-out measurement
11. Move the reflecting prism up or down until the Z coordinate becomes "0.000" to determine the height of the point.
 - data: Move up
 - + data: Move down
12. Press <STOP> to stop the measurement.

14.3 REM setting-out measurement

To set out the point where a target cannot be positioned, perform REM setting-out measurement. See “15. REM measurement” for details of the REM measurement.

► PROCEDURE REM setting-out measurement

1. Set the reflecting prism above or below the object and measure the target height.
2. In 2nd page of S-O mode, press **<Ht.>** and input the target height and the instrument height.
3. Press **<S-O_D>** to input the height difference between the target and the point to be set out.
4. Press **<SO_3D>** for the S-O measurement and **<SO_Ht>** to start REM setting-out measurement.
5. Rotate the telescope up or down until “Ht.” value becomes “0.000m”.
Now the telescope sight at the REM Setting-out point.
6. Press **<STOP>** to stop REM setting-out measurement.

<SO_3D>

<SO_Ht>

Ht.	1.000m	13
ZA	80° 21' 20"	-30
HAR	60° 00' 20"	■2
STOP		

Ht.	0.000m	13
ZA	80° 21' 20"	-30
HAR	60° 00' 20"	■2
STOP		

<STOP>

15. OFFSET MEASUREMENT

- Offset measurement is used to measure the distance or the angle to a point which cannot be sighted or where the target cannot be positioned.

Set the offset point (a point near the target point) and input the distance between the target point and the offset point (distance offset) or set the angle between the target point and the offset point (angle offset). Then measure the offset point. The SET calculates the distance and the angle of the target point.

There are 2 methods of offset measurement

① Distance offset

- When the offset point is positioned to the right or left of the target point, set it so the angle formed by lines connecting the target point to the offset point and to the station point is approximately 90° .
- When the offset point is in front of or behind the target point, set it on the sighting line from the station point to the target point.
- Set the target on the offset point so the target height of the target point and the offset point is the same.

② Angle offset

- Install the offset point as close as possible to the target point to its left or right.

15.1 Distance offset

- Set the offset point to the right or left of the target point so that the angle formed by lines connecting the target point to the offset point and to the station point is almost 90° .
- Set the offset point in front of or behind the target point, on the sighting line from the station point to the target point.

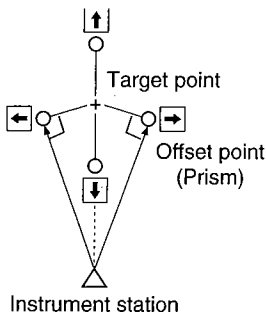

► PROCEDURE

Distance offset

<OFFS>

Offset	13
1. Distance Offset	-30
2. Angle Offset	■2
■1 ■2	Exit

<1>

<Sdist>

<STOP>

S	10.000m	13
ZA	89° 58' 50"	-30
HAR	111° 20' 31"	■2
Sdist Edit	OK	Exit

1. In 3rd page of EDM mode, press <OFFS> and select <1> (Distance offset).
2. Sight the offset point.
3. Press <Sdist> and measure the offset point. (If necessary, press <SHV> to select H distance mode.)
4. Press <STOP> to stop the measurement. The SET displays the distance and the angle of the offset point.
(The measurement mode is set

<Edit>

Dist	1.000m
Direction	hight
Input --- Clear Exit	

<Exit>

S	10.000m	13
ZA	89° 58' 50"	-30
HAR	111° 20' 31"	■2
Sdist	Edit	OK Exit

<OK>

S	10.049m	13	
ZA	89° 52' 54"	-30	
HAR	90° 16' 15"	■2	
Yes	No	Rec	Exit

<Yes> or **<No>** or **<Rec>**

to the previously measured mode. If the previous measurement mode was coordinate mode, the mode is set to the coordinate mode.)

5. Press **<Edit>** and input the distance between the target point and offset point. Then select the position of the offset point (right or left, in front of or behind the target point) using **<←>**.

Press **<Exit>**.

6. Press **<OK>** to calculate the distance and the angle of the target point.
The SET calculates the distance and the angle of the target point and displays them.

7. To record the calculation result (SHV or NEZ), press **<REC>**.
To confirm the result without recording, press **<Yes>**.
To cancel the result, press **<No>**.

- For details about **<REC>**, see "17.3 Instrument station data and measured data recording".

15.2 Angle offset

- Set the offset point as close as possible to the target point to its left or right.

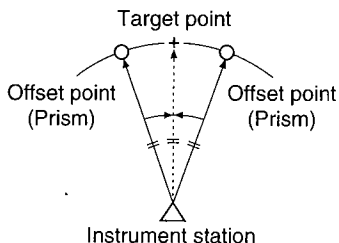

► PROCEDURE

Angle offset

1. In 3rd page of EDM mode, press **<OFFS>** and select **<2>** (angle offset).
2. Sight the offset point and press **<Sdist>** to measure the offset point. (If necessary, press **<▲SHV>** to select H distance mode.)
Press **<STOP>** to stop the measurement. The SET displays the distance and the angle of the offset point.
(The measurement mode is set to the previously measured mode. If the previous measurement mode was coordinate mode, the mode is set to coordinate mode.)

3. Sight the target point using the Horizontal clamp and the Horizontal fine motion screw.
4. Press **<OK>** to calculate the distance and the angle of the target point.
The SET calculates the distance and the angle of the target point and displays them.
5. To record the calculation result , press **<REC>**.
To confirm the result without recording, press **<Yes>**.
To cancel the result, press **<No>**.

- For details about **<REC>**, see **"17.3 Instrument station data and measured data recording"**.

16. REM MEASUREMENT

- When measuring the height of certain objects such as overhead power cables or bridge supports where the reflecting prism cannot usually be positioned, the Remote Elevation Measurement function can be used to calculate the height above the ground using a point directly above or below the object.

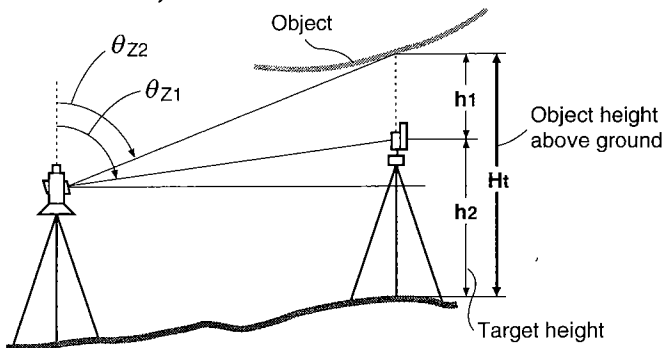

θ_{Z1} : Vertical angle of prism

θ_{Z2} : Vertical angle of object

- The height of the target is calculated using the following formulas.

$$Ht = h_1 + h_2$$

$$h_2 = S \sin \theta_{Z1} \times \cot \theta_{Z2} - S \cos \theta_{Z1}$$

- The measured values are first displayed after 0.7 seconds and then every 0.5 seconds for all measurement modes.

► PROCEDURE Remote elevation measurement

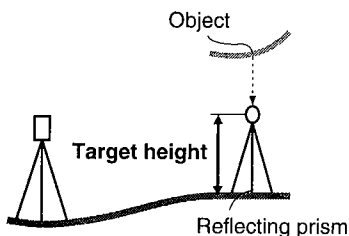

2nd page of S-O mode	
S-O / COORDS	13 - 30
Stn_P Ht. COORD → P3	■2

<Ht.>

1st page of S-O mode	
ZA	91° 57' 20" 13 - 30
HAR	60° 03' 00" ■2

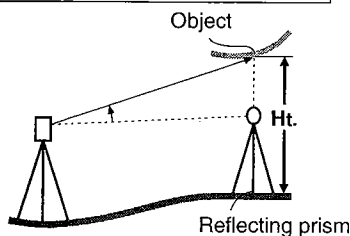

<ESC>

Press function	13
keys to select	- 30
operation	■2
EDM THEO S-O CONF	

<EDM>

1. Set up the reflecting prism above or below object and measure Target height.

2. In 2nd page of S-O mode, press <Ht.> and input the target height.

To set the target height, see "11.2 Target height and instrument height setting".

3. Sight the reflecting prism.

4. Press <ESC> to go to Basic mode.

5. Press <EDM> to go to EDM mode.

1st page of EDM mode

Sdist	13
< Fine average >	-30
	▣2
Sdist	▲SHV THEO →P2

<_dist>

S	12.345 m	13
ZA	80° 21' 20"	-30
HAR	60° 00' 20"	▣2

<STOP>

Object

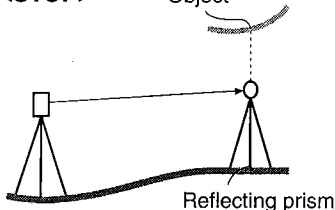

<>PX> <>PX>

REM MLM OFFS →P1

<REM>

Ht.	4.567 m	13
ZA	65° 30' 20"	-30
HAR	60° 00' 20"	▣2
STOP		

<STOP>

6. Press <Sdist>, <Hdist> or <Vdist> and measure the distance. (press <STOP>.)

7. Sight the object, and press <>PX><>PX> to go to 3rd page.

8. Press <REM> to start REM measurement.

The object height is displayed at the first line.

9. Press <STOP> to stop REM.

- The maximum vertical angle: $\pm 89^\circ$ from the horizontal line
(Measuring value limit (Ht.): ± 9999.999 m)



17. DATA MEMORY FUNCTION	89
17.1 Changing the instrument options	91
17.2 Job selecting	92
17.3 Instrument station data and Measured data recording	93
17.4 Instrument station data and Measured data reviewing / deleting / outputting	101
17.5 Feature code inputting / deleting / reviewing	104
17.6 Coordinate data inputting / deleting / reviewing	107



17. DATA MEMORY FUNCTION

- The SET can store data into memory. The data which can be stored are instrument station data and measured data into job files, coordinate data into internal memory and feature code into stack.

The instrument station data, measured coordinate data and recorded coordinate data can be used as instrument station coordinates, backsight station coordinates, known point coordinates, and setting-out coordinates.

- Up to 3000 points can be stored for the instrument station data, measured coordinate data and recorded coordinate data.

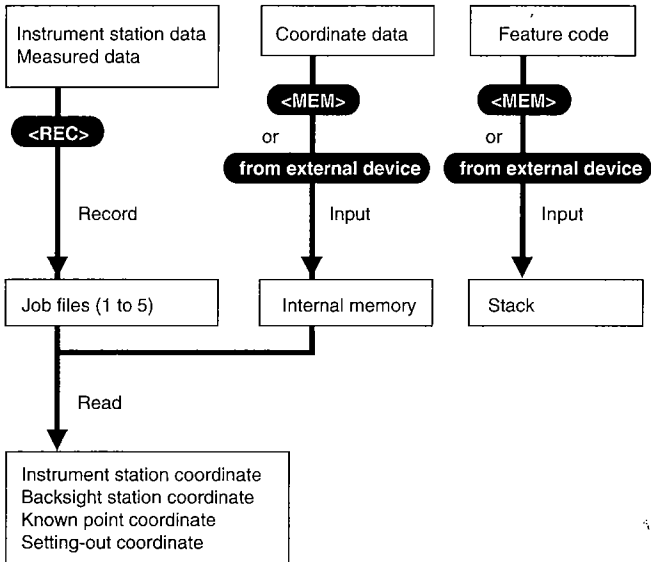

- To use these functions, allocate **<MEM>** and **<REC>** beforehand, referring to chapter 20.

- **Data to be recorded in Record mode**

Strn_P	Feature code, instrument station number, instrument height, temperature, atmospheric pressure, atmospheric correction value, prism constant correction value and instrument station coordinates
N,E,Z (E, N, Z)	Feature code, point number, target height, N coordinate*, E coordinate* and Z coordinate*
V,H	Feature code, point number, target height, vertical angle* and horizontal angle*
S,V,H	Feature code, point number, target height, slope distance*, vertical angle* and horizontal angle*

Items with “*” cannot be input in Record mode.

The feature code and instrument station coordinates can be read from the internal memory or selected job.

To record the feature code, refer to “**17.5 Feature code recording / deleting / reviewing**”. To record the coordinate data, please refer to “**17.3 Instrument station data and Measured data recording**” and “**17.6 Coordinate data inputting / deleting / reviewing**”.

- **Memory mode menu**

Job	Selecting job
Code	Recording, deleting and reviewing feature code
Data	Outputting, reviewing and deleting the measured data stored in the job
Coordinates	Inputting data, deleting and reviewing the input data stored in the memory

17.1 Changing the Instrument options

- Confirm that these parameters are set according to the data recording conditions.
- To confirm or change the parameter options, refer to "20. CHANGING INSTRUMENT PARAMETERS".

Parameter	Options
Point number increment	001* (001 to 999)
Xon / Xoff	1. Yes* 2. No
Checksum	1. Yes 2. No*

*: Factory setting

17.2 Job selecting

- The SET can store the instrument station data and measured data in job files. Select the job file to which the data is to be recorded before recording the data.

► PROCEDURE Job selecting

In 3rd page of S-O mode

<MEM>
<↓> <↑>

<Enter>

<↓> <↑>

<Enter>

1. Press <MEM> for Data memory mode.
2. Press <↑> or <↓> to display "Job".
3. Press <Enter> for Job selecting mode.
4. Press <↑> or <↓> to display the required job name.
5. Press <Enter> to select the job name.
(The display returns to Data memory mode)

- Job name can be selected from 5 jobs, "JOB1", "JOB2", "JOB3", "JOB4" and "JOB5"

17.3 Instrument station data and Measured data recording

- The following items can be recorded as instrument station data: feature code, instrument station number, instrument height, temperature, atmospheric pressure, atmospheric correction value, prism constant correction value and instrument station coordinates.

► PROCEDURE Instrument station data recording

In any page of any mode

<REC>

<↓>

Record mode

■ REC Job1

Stn_P

Free recs 2989

■ ↓ ■ Rec Edit Exit

1. Press <REC> for Record mode and <↓> to display "Stn_P".

<Edit>

Stn_P

Code

■ ↓ ■ Rec Input Exit

2. Press <Edit> to go to Instrument station data input mode.

<Input>

3. Press <Input> to set Feature code for Instrument station.

4. Set Feature code for Instrument station.

To input Feature code

Cd

■ ↓ ■ Sel ■ → ■ Enter

(N) Numeric input (A: Alpha input)

1st page

- Display next function: <↓>
- Display next character: <Sel>
- Go to next column: <→>

2nd page

- Delete character at left: <BSp>
- Go to previous column: <←>
- Read Feature codes from Stack
<List>

3rd page

- Toggles between alpha and numeric input: <A/N>
- Clear the code data: <Clear>

Input Feature code and press
<Enter> to set Feature code.

- Feature code can be up to 13 characters long
- Characters allowed are "A" to "Z", "0" to "9", "_", "-", ".", and "&"

To read Feature code from Stack



<List>

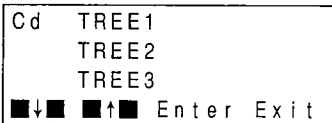

<↓> and <↑>

<Enter>

Press <List> to read Feature codes and display the required code using <↑> and <↓>.

Then press <Enter> to input Feature code.

<↓>

Stn_P
No.00000001
■↓■ Rec Input Exit

<Input>

<↓><↑>

<Enter>

<↓>

Stn_P
InstrHt. 0.000m
■↓■ Rec Input Exit

<Input>

<↑>, <↓> and <←>

<Enter>

<↓>

Temp. 15° C
Press 1013hPa
ppm 0
■↓■ Rec Input Exit

5. Press <↓> to display Instrument station number.

6. Press <Input> to input Instrument station number and input Instrument station number using <↑> (count up) and <↓> (count down), then press <Enter> to set Instrument station number.

7. Press <↓> to display "InstrHt".

8. Press <Input> to input Instrument height and input Instrument height using <↑> (count up) and <↓> (count down), then press <Enter> to set Instrument height.

• Input range: -9999.999 to 9999.999m • Least input: 0.001m

9. Press <↓> to display "Temp.", "Press." and "ppm".

<Input>

Temp.	+15°C
Press	1013hPa
ppm	0
 Enter	

10. Press **<Input>** to set Atmospheric correction value.

11. Input Temperature using **<↑>** (count up) and **<↓>** (count down) and press **<Enter>**. Then input Pressure and press **<Enter>** (ppm value is calculated automatically and displayed.)

If required, input ppm value and press **<Enter>**.

- Temperature input range: -30 to 60°C
- Pressure input range: 500 to 1400hPa
- ppm input range: -499 to 499ppm
- Least input: 1°C
- Least input: 1hPa
- Least input: 1ppm

<↓>

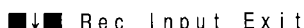
Stn_p	
PC	-30mm
 Rec Input Exit	

<Input>

12. Press **<↓>** to display "PC".

13. Press **<Input>** to input Prism constant correction value.

PC = -30
 Enter

<↑>, **<↓>** and **<→>**

<Enter>

14. Input Prism constant correction value using **<↑>** (count up) and **<↓>** (count down), and press **<Enter>** to set Prism constant correction value.

- Input range: -99 to 0mm
- Least input: 1mm

<↓>

Stn N	0.000
E	0.000
Z	0.000
■↓■ Rec Input Exit	

<Input>

15. Press <↓> to display
"Stn N, E, Z".

16. Press <Input> to set Instrument
station coordinate.

17. Set Instrument station
coordinate.

To input Instrument station coordinate

Stn N	0.000
E	0.000
Z	0.000
Input Read Clear Exit	

<Input>

Stn N	+000000.000
E	+000000.000
Z	+000000.000
■↑■ ■↓■ ■→■ Enter	

<↑>, <↓> and <→>

<Enter>

Press <Input> to set up input of
Instrument station coordinate, then
input N coordinate using <↑>
(count up) and <↓> (count down),
then press <Enter> to set N
coordinate.

Input E and Z coordinates in the
same way.

- Input range: -999999.999 to 999999.999m
- Least input 0.001m
- Retain the displayed value: <Exit>
- Set the value to 0: <Clear>
- Exit from the mode: <ESC>

To read Instrument station coordinates

Stn N	0.000
E	0.000
Z	0.000
Input Read Clear Exit	

<Read>

Coord	00000001
Stn_p	00001001
N, E, Z,	00010001
<input type="checkbox"/> ↓ <input type="checkbox"/> <input type="checkbox"/> ↑ <input type="checkbox"/>	Enter Exit

<↑>, <↓>

<Enter>

Stn N	123456.000
E	123456.000
Z	0.000
Yes No	

<Yes>

Stn N	123456.000
E	123456.000
Z	0.000
<input type="checkbox"/> ↓ <input type="checkbox"/>	Rec Input Exit

<Rec>

- After angle measurement, distance measurement or coordinate measurement, the stored data measured most recently can be recorded in the selected job.
- The following items can be recorded:
 V, H: Feature code, point number, target height, atmospheric correction value, measured vertical and horizontal angle*.

Press **<Read>** to read Instrument station coordinate.

- Coord: Data in the memory
- Stn_p: Data in the selected JOB
- N, E, Z: Data in the selected JOB

Display the required point number at the first line using **<↓>** and **<↑>** and press **<Enter>**.

18. Press **<Yes>** to set the displayed coordinates as Instrument station coordinates.

19. Press **<Rec>** to record Instrument station data. (1st page of former mode)

S, V, H: Feature code, point number, target height, atmospheric correction value, measured slope distance*, vertical angle and horizontal angle*.

N, E, Z: Feature code, point number, target height, atmospheric correction value and measured coordinates*.

Items with "*" cannot be input in Recode mode.

► PROCEDURE Measured data recording

<Rec>

In any page of any mode after required measurement

Record mode

```

■ REC          JOB1
  Stn_p
  Free recs 2989
  ■↓■ Rec Edit Exit
  
```

1. Press <REC> for Record mode.

Job name

Available number for data recording

<↓>

2. Press <↓> to display "N,E,Z", "V,H" or "S,V,H".

```

■ REC          JOB1
  V,H
  Free recs 2989
  ■↓■ Rec Edit Exit
  
```

3. Press <Edit> to set Measured point data.

<Edit>

```

V,H
  No.00000001
  ■↓■ Rec Input Exit
  
```

4. Press <Input> to set up to input of Point number.

<Input>

<↑>, <↓> and <->

<Enter>

5. Input Point number using <↑> (count up) and <↓> (count down), and press <Enter> to set, Point number.

<↓>

```
V, H
Code
█↓█ Rec Input Exit
```

<Input>

```
Cd POINT1
█↓█ Sel █→█ Enter
```

6. Press <↓> to display "Code".

7. Press <Input> to set Feature code.

- Display next function: <↓>
- Display next character: <Sel>
- Go to next column: <→>
- Delete character at left: <BSp>
- Go to previous column: <←>
- Toggles between alpha and numeric input: <A/N>
- Clear the code data: <Clear>

8. Input Feature code.

9. Press <Enter> to set Feature code.

- Feature code can be up to 13 characters long
- Feature code characters allowed are "A" to "Z", "0" to "9", ".", "-", ":", and "&"

<↓>

```
ZA 102° 52' 10"
HAR 277° 39' 20"
█↓█ Rec Exit
```

<Rec>

```
JOB1 Free recs 1234
No. 00000001
V, H Record end
█↓█ Rec Edit Exit
```

10. Press <↓> to display Measured data.

11. Press <Rec> to record Measured data.

- While recording the data, job name, available number and point number are displayed.
- After that, the display returns to the 1st page of former mode.

17.4 Instrument station data and Measured data reviewing / deleting / outputting

- The instrument station data and measured data stored in the memory for each job can be displayed, deleted or output.
- Select the required job beforehand, referring to “17.2 Job selecting”.

► PROCEDURE Data reviewing / deleting / outputting

<MEM>

In any page of any mode

```

  Data memory mode
  ┌───────────────────┐
  │ ■ Memory          │
  │   Job             │
  │ ───────────────── │
  │ ■↓ ■↑ ■ Enter Exit │
  └───────────────────┘
  
```

1. Press <MEM> for Data memory mode.

<↓>

2. Press <↓> to display “Data”.

```

  ■ Memory
  Data                JOB1
  ─────────────────
  ■↓ ■↑ ■ Enter Exit
  
```

3. Press <Enter> to output, delete or review the data.

<Enter>

To review the data

```

  1. Data output  2700
  2.      delete
  3.      view
  ───────────
  ■1 ■2 ■3 Exit
  
```

- ① Press <3> for Data reviewing mode.

<3>

- ② Display the required point number at the first line using <↓> and <↑>.

```

  Coord  00000001
  Stn_p  00001001
  N, E, Z 00010001
  ───────────
  ■↓ ■↑ ■ Enter Exit
  
```

- Stn_p: Instrument station data
- N, E, Z: Measured coordinate data
- Coord: Recorded coordinate data

<↓> <↑>

<Enter>

```

No.      00000001
Code     ABC
InstrHt  1.500m
  █↓█ Next Prev Exit

```

<↓>, **<Next>** or **<Prev>**

③ Press **<Enter>** to review the data.

④ Display the required data.

- Display other data: **<↓>**
- Go to next point data: **<Next>**
- Go to previous point data: **<Prev>**

⑤ Press **<Exit>** to end.

To delete the data

```

Data output 2700
2.         delete
3.         view
  █1█  █2█  █3█ Exit

```

<2>

```

Coord  00000001
Stn_p  00001001
N,E,Z  00010001
  █↓█  █↑█ ALL Enter

```

<ALL>

```

ALL Data

           delete ?
Yes  No

```

<Yes>

① Press **<2>** for Data deleting mode.

The data is displayed in the order of recording.

- Stn_p: Instrument station data
- N, E, Z: Measured coordinate data
- Coord: Recorded coordinate data

② Press **<ALL>** and **<Yes>** if deleting all data.

<↑><↓>

<Enter>

```

No. 12345678

      delete ?
Yes  No

```

<Yes>

```

1. Data output 2700
2.      delete
3.      view
■1■  ■2■  ■3■ Exit

```

- To delete a line of data, press <↑> or <↓> to display the point number to be deleted at the first line, and press <Enter>. Then press <Yes> to delete the displayed coordinate data.
- After deleting the data, the display returns as at left.

- Exit from the mode: <ESC> (To Basic mode)

To output the data

```

1. Data output 2700
2.      delete
3.      view
■1■  ■2■  ■3■ Exit

```

- Press <1> for Data output mode.

<1>

```

RS232C Output

Yes  No

```

- Press <Yes> to output the data.

<Yes>

```

RS232C Output

      0
Exit

```

Number of data output

```

1. Data output 2700
2.      delete
3.      view
■1■  ■2■  ■3■ Exit

```

- After outputting the data, the display returns as at left.

- Stop outputting: <Exit>

17.5 Feature code inputting / deleting / reviewing

- The SET can input the feature codes in the memory in advance. These data can be used when recording the instrument station data and measured data.

► PROCEDURE Feature code inputting / deleting / reviewing

<MEM>

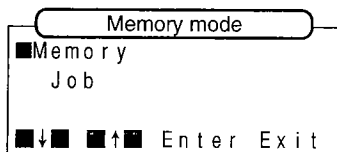

<↓>

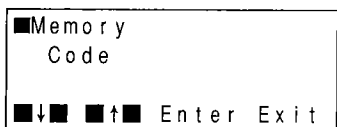

<Enter>

In any page of any mode

1. Press <MEM> for Data memory mode.
2. Press <↓> to display "Code".
3. Press <Enter> to input, delete or review Feature code.
4. Input/delete/view Feature code.

To input Feature code

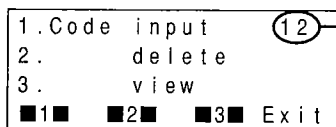

<1>

Available number of Feature codes stored in the memory

- ① Press <1> for Feature code input mode.



Numeric input (A: Alpha input)

1st page

■↓■ Sel ■→■ Enter

2nd page

■↓■ BSp. ■←■ List

3rd page

■↓■ A/N Clear

■↓■ Sel ■→■ Enter

<Enter>

1st page

- Display next function: <↓>
- Display next 1 character: <Sel>
- Go to next column: <→>

2nd page

- Delete left character: <BSp>
- Go to previous column: <←>

3rd page

- Toggles between alpha and numeric input: <A/N>
- Clear the code data: <Clear>

② Input Feature code.

③ Press <Enter> to set Feature code.

- Feature code can be up to 13 characters long
- Up to 40 Feature codes can be input
- Characters allowed are "A" to "Z," "0" to "9," "_," "-", ".", "*" and "&"

To delete Feature code

1. Code input 12
 2. delete
 3. view
■1■ ■2■ ■3■ Exit

<2>

Cd TREE1
 TREE2
 TREE3
■↓■ ■↑■ ALL Enter

<ALL>

ALL Code data
 delete ?
 Yes No

<Yes>

Press <2> for Feature code delete mode.

Feature codes are displayed in the order of recording.

- Press <ALL> if deleting all data. Then press <Yes> to delete all data.

<↑> <↓>

<Enter>

Cd	TREE1
	delete ?
Yes	No

<Yes>

- To delete a Feature code, press <↑> or <↓> to display the Feature code to be deleted at the first line, and then press <Enter>.

Then press <Yes> to delete the displayed feature code.

To review Feature code

1.	Code input	12
2.	delete	
3.	view	
■1■	■2■	■3■ Exit

<3>

Cd	TREE1		
	TREE2		
	TREE3		
■↓■	■↑■	ALL	Enter

<↑> <↓>

Press <3> for Feature code review mode.

Feature codes are displayed in the order of recording.

- Go to previous Feature code: <↑>
 - Go to next Feature code: <↓>
5. Press <Exit> to end.

17.6 Coordinate data inputting / deleting / reviewing

- The SET can input the coordinate data into memory in advance. These data can be used as instrument station coordinates, backsight station coordinates, known point coordinates, and setting-out coordinates.

► PROCEDURE Coordinate data inputting/deleting/reviewing

<MEM>

Data memory mode

■ Memory
Job

■↓ ■↑ ■ Enter Exit

<↓>

■ Memory
Coordinates

■↓ ■↑ ■ Enter Exit

<Enter>

In any page of any mode

- Press <MEM> for Memory mode.
- Press <↓> to display "Coordinates".
- Press <Enter> to input, delete or review Coordinate data.

To input Coordinate data - For Coordinate data input by key-in

Coordinates
input

Free recs 2900

■↓ ■↑ ■ Enter Exit

<↓> <↑>

<Enter>

Number of empty data records available

- Press <↑> or <↓> to display "input".
- Press <Enter> for Coordinate data input mode.

```

P      N +000000.000
      E +000000.000
      Z +000000.000
  █↑█ █↓█ █→█ Enter

```

<↑>, <↓> and <→>

<Enter>

```

Coord.
  No. 00000001
  █↑█ █↓█ █→█ Enter

```

<↑>, <↓> and <→>

<Enter>

- Coordinate data input range: -999999.999 to 999999.999m
- Coordinate data least input: 0.001m
- Point number input range: 1 to 99999999
- Exit from the input: <ESC> (To Basic mode)

For Coordinate data input from an external device in SDR33 format

```

Coordinates
  RS232C
Free recs 2900
  █↓█ █↑█ Enter Exit

```

<↓><↑>

<Enter>

```

RS232C Input

  Yes  No

```

<Yes>

- ③ Input N coordinate data using <↑> (count up) and <↓> (count down), and press <Enter> to set N coordinate data.

- ④ Input E and Z coordinate data in the same way.

- ⑤ Input the point number using <↑> (count up) and <↓> (count down), and press <Enter> to set the point number.

- ① Press <↑> or <↓> to display "RS232C".

- ② Press <Enter> for coordinate data input from external device mode.

- ③ Press <Yes> to input Coordinate data from external device.

```

RS232C Input
          (0)
          Exit
  
```

Number of Coordinate data input from external device

- ④ Input Coordinate data from external device.

To delete Coordinate data

```

Coordinates
  delete
Free recs 2900
█↓█ █↑█ Enter Exit
  
```

- ① Press <↑> or <↓> to display "delete".

<↓><↑>

<Enter>

- ② Press <Enter> for coordinate data deleting mode.

```

Coord. 10000000
Coord. 10000005
Coord. 10000010
█↓█ █↑█ ALL Enter
  
```

<ALL>

- Press <ALL> if deleting all data. Then press <Yes> to delete all data.

```

ALL Coord. data
      delete ?
Yes  No
  
```

<Yes>

<↓><↑>

<Enter>

- To delete a data, press <↑> or <↓> to display the point number to be deleted at the first line and press <Enter>. Then press <Yes> to delete the displayed coordinate data.

```

No. 10000000
      delete ?
Yes  No
  
```

<Yes>

To review Coordinate data

```
Coordinates
  view
Free recs 2900
■↓■ ■↑■ Enter Exit
```

<↓><↑>

<Enter>

```
Coord. 10000000
Coord. 10000005
Coord. 10000010
■↓■ ■↑■ Enter Exit
```

<↓><↑>

<Enter>

```
No. 10000000
■↓■ Next Prev Exit
```

<↓>

```
P  N 100000.000
   E 100000.000
   Z 100000.000
■↓■ Next Prev Exit
```

<↓> <Next> <Prev>

① Press <↑> or <↓> to display "view" and press <Enter> for coordinate data viewing mode.

② Display the required point number at the first line.

③ Press <Enter> to select the point number.

④ Press <↓> to display Coordinates.

- Display other data: <↓>
- Go to next point data: <Next>
- Go to previous point data: <Prev>

⑤ Display the required coordinate data.

18. ERROR MESSAGES	113
19. CHECKS AND ADJUSTMENTS	116
19.1 Plate level	116
19.2 Circular level	118
19.3 Tilt sensor	119
19.4 Reticle	123
19.5 Optical plummet	128
19.6 Distance measurement check flow chart	130
19.7 Additive distance constant	131



18. ERROR MESSAGES

- When an error message is displayed, take the action described in the table below.
- If the same error message is repeated or if other messages are shown, please contact your SOKKIA agent.

Message	Meaning	Action
Bad condition	Prism sighting is bad.	Sight the target correctly again. Measure again after confirming the returned signal.
Backup battery low!	Lithium battery becomes low.	Contact your SOKKIA agent to replace the lithium battery. When the battery is replaced all data is cleared.
Backup battery low! Power off?	Lithium battery is low.	Press <No> to download the data stored in memory before power-off. Press <Yes> to switch the power off and all data will be cleared.
Battery is low!	Battery voltage is too low.	Charge the battery or replace it with a charged one.
Data checksum error!	3000 points data and code are damaged.	
	Lithium battery is low.	Contact your SOKKIA agent to replace the lithium battery. When the battery is replaced all data is cleared.

Message	Meaning	Action
Data write error!	Data cannot be stored.	Contact your SOKKIA agent.
Memory full !	Memory is full.	
No data	Error when measuring the initial slope distance during either REM or horizontal distance between 2 points measurement.	Sight the reflecting prism to perform slope distance measurement again.
	There is no coordinate data or Feature code in the memory.	
Out of range	During the distance measurement, the tilt angle exceeds $\pm 3'$.	Level the SET again.
Out of value	During REM, the vertical angle is more than $\pm 89^\circ$ or the measured distance is more than 9999.999m.	Press <STOP> to stop the measurement.
RAM cleared	Data stored in the memory has been cleared.	
RS232C input checksum error	A checksum error occurred.	Press <EXIT>.
RS232C input Memory full	Memory is full.	
RS232C input receive error	SET failed to take data from an external device.	Check the RS-232C communication format.

Message	Meaning	Action
RS232C input receive data error	An error has occurred in the received data.	Check if the data is correct.
RS232C input receive time out	No data is received from an external device.	Press <Exit> to stop inputting the data from an external device.
RS232C input send time out	Output has paused because an Xoff character was received.	Press <Exit> to stop outputting the data to an external device.
Signal off	At start of measurement or during the measurement, the returned signal was totally absent or disturbed.	Sight the target correctly again.
	No measured distance data is received within 2 minutes of starting the measurements, or the measured distance data cannot be obtained for a total of 1 minute.	Measure again after confirming the returned signal.
Tilt out of range X- > \perp + Y- \perp <+	The tilt sensor range error. The tilt angle exceeds $\pm 3'$.	Level the SET again.
E 100	Error when measuring a horizontal angle.*	Index the horizontal circle again.
E 101	Error when measuring a vertical angle.*	Transit the telescope again.

* If the SET telescope or upper part is rotated faster than 4 revolutions per second, the error indication "E 100" or "E 101" is displayed.

19. CHECKS AND ADJUSTMENTS

- Periodically, checks and adjustments should be performed before and during measurement. In addition, the instrument should be checked after long storage, transportation or when damage to the instrument is suspected to have occurred due to a strong shock.

► **NOTE** The checks should be performed in the following order.

19.1 Plate level

- The glass tube of the plate level is sensitive to temperature changes or shock.

► PROCEDURE **Check**

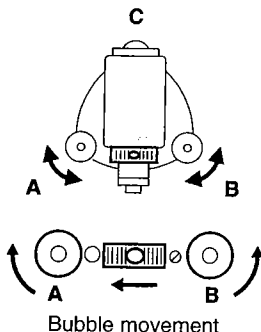

- Turn the upper part of the instrument until the plate level ⑫ is parallel to a line between levelling foot screws A and B. Center the plate level bubble using levelling foot screws A and B. The bubble moves towards a clockwise rotated levelling foot screw.

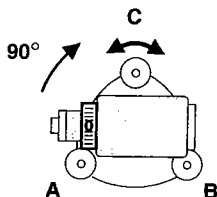

- Loosen the horizontal clamp ⑬ and turn the upper part 90°. The plate level is perpendicular to a line between levelling screws A and B.

- Center the plate level bubble using levelling screw C.

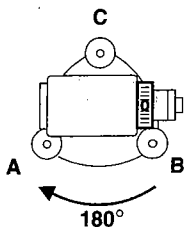

- Turn the upper part through 180° and check the bubble position.
If the bubble is still centered, no adjustment is necessary.
If the bubble is off-center, adjust as follows:

► PROCEDURE Adjustment

Use levelling screws

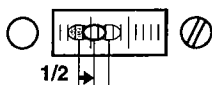

Use adjusting pin

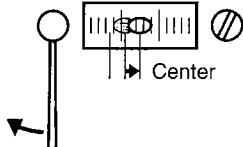

- Correct half of the bubble displacement using levelling foot screw C.
- Correct the remaining half of the displacement by adjusting the screw ② with the adjusting pin.
The bubble moves towards a clockwise rotation of the adjusting screw.
- Repeat the procedures from 1 to 6 until the bubble remains centered for any position of the upper part.

If the bubble cannot be centered, please contact your SOKKIA agent.

19.2 Circular level

► PROCEDURE

Check

1. Perform the plate level adjustment or level the instrument carefully using the plate level.
2. Check the position of the circular level bubble.
If the bubble is still centered, no adjustment is necessary.
If the bubble is off-center, adjust as follows:

Adjustment

Circular level adjusting screws

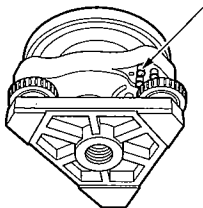

3. Verify the off-center direction of the bubble.
4. Loosen the adjusting screw ⑦ farthest from that direction to center the bubble.
5. Adjust all 3 adjusting screws until the tightening tension of each screw is the same, and the bubble is centered.

► **NOTE** Over-tightening the adjusting screws may damage the circular level. Unequal tightening of the screws may mean that the bubble will go out of adjustment.

If the bubble cannot be centered, please contact your SOKKIA agent.





19.3 Tilt sensor

- If there is a tilt 0 point error, the tilt angle is not 0 when the instrument is levelled, and it causes an angle error. This tilt 0 point error can be checked and adjusted as follows.

► PROCEDURE Check

Basic mode
Press function
keys to select
operation 2
EDM THEO S-O CONF

<CONF>

Setting mode
1. Configuration
2. Tilt correction
3. Key select
1 2 3  Exit

<2>

Tilt sensor checking mode
HAR 90° 00' 00"
Tilt X -0° 00' 20"
Y -0° 00' 40" 2

e.g.: $X_1 = -20$

$Y_1 = -40$

HAR 270° 00' 00"
Tilt X 0° 00' 40"
Y -0° 00' 20" 2

- Carefully level the SET.
- In Basic mode, press <CONF> for Setting mode.
- Press <2> for Tilt sensor checking mode.
- Wait for a few seconds until the tilt angle readings are steady, and note the tilt angle values X_1 and Y_1 .
1st line: Horizontal angle
2nd line: Tilt angle of X direction
3rd line: Tilt angle of Y direction
- Loosen the horizontal clamp  and turn the theodolite through 180° referring to the horizontal angle display. Tighten the horizontal clamp.

e.g.: $X_2 = 40$
 $Y_2 = -20$

e.g.:

X direction = $(-20+40) / 2=10$

Y direction = $\{-40+(-20)\} / 2=-30$

6. When the tilt angle readings are steady, note the tilt angle values, X_2 and Y_2 .

7. Calculate the offset values.

$$(X_1 + X_2) / 2$$

$$(Y_1 + Y_2) / 2$$

If the offset value (X and Y) are $\pm 10''$ or less, no adjustment is necessary.

Press **<Exit>** to finish the check.

If one of the offset values is greater than $\pm 10''$, the sensor index should be adjusted as follows without pressing **<Exit>**.

► PROCEDURE Adjustment

<OSET>

Tilt sensor adjusting mode			
HAR	0° 00' 00"		
Tilt X	0° 00' 40"		
>F1 Y	-0° 00' 20"	■	2
SET		Exit	

<SET>

HAR	0° 00' 00"		
Tilt X	0° 00' 40"		
>F2 Y	-0° 00' 20"	■	2

HAR	180° 00' 00"		
Tilt X	0° 00' 40"		
>F2 Y	-0° 00' 20"	■	2
SET		Exit	

8. Press **<OSET>** for Tilt sensor adjusting mode.

The horizontal angle becomes 0° .

9. Press **<SET>** to memorize tilt angle X_2 and Y_2 .

10. Loosen the horizontal clamp and turn the upper part through 180° , referring to the horizontal angle display.

<SET>

X=0398	Y=0440
Tilt X -0° 00' 20"	
Y -0° 00' 40"	■2

e.g.: Tilt 0 point data

X =398

Y =440

11. When the tilt angle readings are steady, press **<SET>** to memorize X2 and Y2.

The tilt 0 point data is displayed at the 1st line.

If the tilt 0 point data is greater than 400 ± 120 , press **<Exit>** to stop the adjustment (Please contact your SOKKIA agent).

If it is 400 ± 120 or less, continue the adjustment without pressing **<Exit>**.

<Enter>

Tilt sensor checking mode

HAR 180° 00' 00"	
Tilt X 0° 00' 00"	
Y -0° 00' 10"	■2

e.g.: $X_3 = 0$ $Y_3 = -10$

12. Press **<Enter>** to store the new Tilt 0 point data.
(Tilt sensor checking mode)

The adjusted new tilt angle values, X and Y are displayed.

13. When the tilt angle readings are steady, note the tilt angle value, X3 and Y3.

14. Loosen the horizontal clamp and turn the upper part through 180° .

15. When the tilt angle readings are steady, note the Tilt angle value, X4 and Y4.

HAR 0° 00' 00"	
Tilt X -0° 00' 10"	
Y 0° 00' 00"	■2

e.g.: $X_4 = -10$ $Y_4 = 0$

e.g.:

X direction = $\{0+(-10)\} / 2 = -5$

Y direction = $(-10+0) / 2 = -5$

<Exit>

Input ppm value			
1.	Configuration		
2.	Tilt correction		
3.	Key select		
■1■	■2■	■3■	Exit

16. Calculate the offset values.

$$(X_3 + X_4) / 2$$

$$(Y_3 + Y_4) / 2$$

If the offset values (X and Y) are $\pm 10''$ or less, the adjustment has been finished.

17. Press **<Exit>** to finish the check.

(Setting mode)

If one of the offset values are greater than $\pm 10''$, repeat the adjustment procedures.

- Exit from the mode: **<Exit>**
- If the offset values are greater than $\pm 10''$, in spite of repeating the adjustment, please contact your SOKKIA agent.

19.4 Reticle

- This adjustment is very delicate. If you have any difficulties, please contact your SOKKIA agent.

► **IMPORTANT** Make sure that no dirt, dust or water becomes attached to the inside of the telescope reticle cover when it is removed to adjust the reticle. After adjustment, securely reattach the reticle cover. Any water or dust on the inside of the reticle cover will reduce the instruments capacity for water resisting. (SET5W/5WS)

► **PROCEDURE** **Check 1 <Perpendicularity of the reticle to the horizontal axis>**

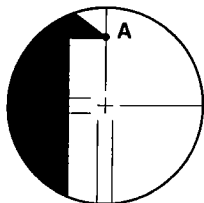

1. Carefully level the SET.
2. Select and sight a clear target on the upper part A of the reticle line.
3. Turn the telescope vertical fine motion screw ②5 until the target is on the lower part of the reticle B.

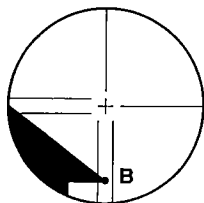

Check that the target is still positioned centrally within the reticle lines.
If the target is off-center, adjust as follows:

Adjustment 1

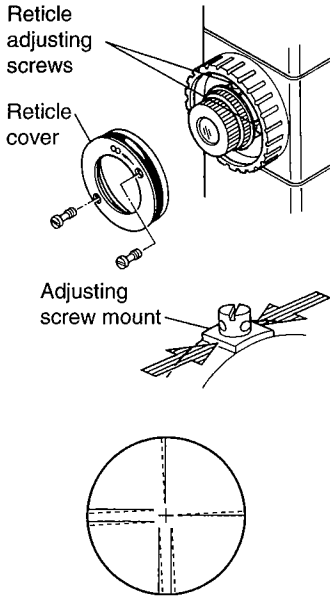

4. Remove the telescope reticle cover.
5. Slightly loosen one vertical and one horizontal adjustment screw by an equal amount using the adjusting pin.
6. Place a small piece of plastic or wood against one side of the top adjusting screw mount as a buffer.
7. Look through the eyepiece and gently tap the piece of plastic or wood to rotate the reticle slightly.
8. Retighten the two adjusting screws loosened in step 5 by the same amount.

► **NOTE** Over-tightening the adjusting screws may damage the reticle. Unequal tightening of the adjusting screws may mean that the reticle will go out of adjustment.

8. Check the reticle perpendicularity again using procedures 1 and 2 above and repeat the adjustment if necessary.

9. Replace the reticle cover.

- **NOTE** After this adjustment, perform the check and adjustment of the reticle position as follows.

Check 2 (Vertical and horizontal reticle line positions)

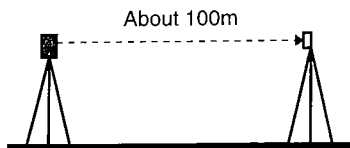

1. Set up a clear target 100m (328ft) from the SET.
2. Carefully level the SET, switch the power on and index the vertical and horizontal circles.
3. Sight the target on face left. Read the horizontal angle A_1 and vertical angle B_1 .

ZA	90° 30' 20"	
HAR	18° 34' 00"	2

e.g.: H angle $A_1 = 18^\circ 34' 00''$
V angle $B_1 = 90^\circ 30' 20''$

Telescope face right

ZA	269° 30' 00"	
HAR	198° 34' 20"	2

e.g.: H angle $A_2 = 198^\circ 34' 20''$
V angle $B_2 = 269^\circ 30' 00''$

e.g.:

$$\begin{aligned} \text{H angle } A_2 - A_1 & \\ &= 198^\circ 34' 20'' - 18^\circ 34' 00'' \\ &= 180^\circ 00' 20'' \end{aligned}$$

$$\begin{aligned} \text{V angle } B_2 + B_1 & \\ &= 269^\circ 30' 00'' + 90^\circ 30' 20'' \\ &= 360^\circ 00' 20'' \end{aligned}$$

4. Now sight the target on face right and read the horizontal angle A_2 and vertical angle B_2 .
5. Calculate $A_2 - A_1$ and $B_2 + B_1$.
 $A_2 - A_1$ should be within $180^\circ \pm 20''$
 $B_2 + B_1$ should be within $360^\circ \pm 20''$.
If a difference of more than $\pm 20''$ still remains after repeating these procedures several times, adjust as follows.

Adjustment 2

► **IMPORTANT** Moving the reticle line effects the distance measurement.

Do not move the reticle more than 20".

e.g.: H angle $A_1 = 18^\circ 34' 00''$
 V angle $B_1 = 90^\circ 30' 10''$
 H angle $A_2 = 198^\circ 34' 20''$
 V angle $B_2 = 269^\circ 30' 10''$

ZA	269° 30' 00"
HAR	198° 34' 10" ■ 2

6. Calculate the horizontal angle A and vertical angle B.

$$A = (A_2 + A_1) / 2 + 90^\circ$$

$$B = (B_2 - B_1) / 2 + 180^\circ$$

7. While still sighting the target on face right, use the horizontal and vertical fine motion screws to adjust the displayed horizontal and vertical angles to the above values.

8. Look through the telescope. The reticle is now slightly shifted from the target.

9. Remove the telescope reticle cover.

10. To move the vertical reticle line towards the target center, loosen the right and left adjusting screws using the adjusting pin.

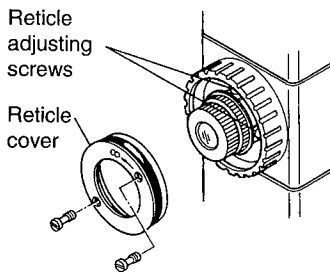

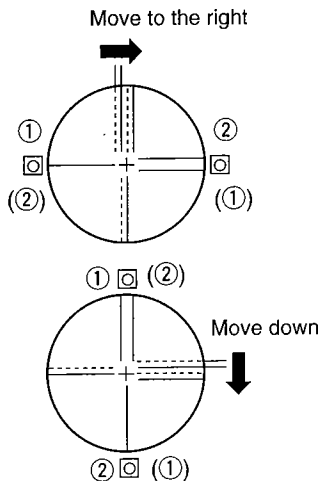

To move the reticle to the right (left):

- ① very slightly loosen the left (right) adjusting screw,
- ② tighten the right (left) adjusting screw by the same amount.

To move the horizontal reticle line towards the target center, loosen the top and bottom adjusting screws using the adjusting pin.

To move the reticle down (up):

- ① slightly loosen the top (bottom) adjusting screw,
- ② tighten the bottom (top) adjusting screw by the same amount.

[() for opposite direction]

- **NOTE** Over-tightening the adjusting screws may damage the reticle. Unequal tightening of the adjusting screws may mean that the reticle will go out of adjustment.

11. Finally tighten the top and bottom adjusting screws as before.

Check the reticle position and repeat the procedure until the reticle comes close to the target center.

12. Replace the reticle cover.

19.5 Optical plummet

- **IMPORTANT** Make sure that no dirt, dust or water becomes attached to the inside of the optical plummet cover when it is removed to adjust the optical plummet. After adjustment, securely reattach the optical plummet cover. Any water or dust on the inside of the optical plummet will reduce the instruments capacity for water resisting. (SET5W/5WS)

► PROCEDURE **Check**

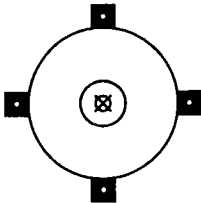

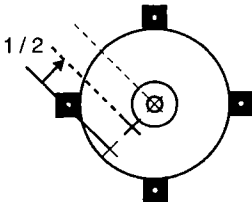

1. Carefully level the SET and exactly center a surveying point in the reticle of the optical plummet.
2. Turn the upper part 180° and check the position of the surveying point in the reticle. If the surveying point is still centered, no adjustment is necessary. If the surveying point is not still centered in the optical plummet, adjust as follows:

► PROCEDURE **Adjustment**

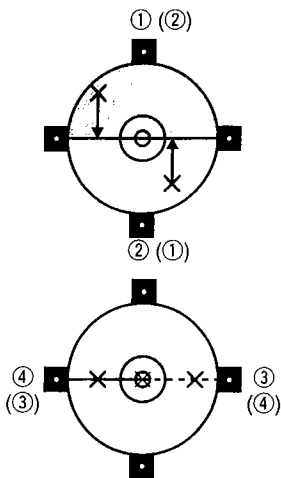

3. Correct half the deviation with the levelling foot screw ⑨.
4. Unscrew the optical plummet reticle cover ⑫ to adjust the remaining half of the displacement with the 4 adjusting screws.



5. When the surveying point is on the part shown in  () area:

- ① Loosen the upper (lower) screw slightly,
- ② tighten the lower (upper) screw by the same amount.

6. Next, if the surveying point is seen to be on the part shown in solid line (dotted line):

- ③ Loosen the right (left) screw slightly,
- ④ tighten the left (right) screw by the same amount.

► **NOTE** Over-tightening the adjusting screws may mean that the reticle will go out of adjustment.

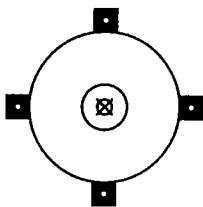

7. Check the adjustment by rotating the upper part of the instrument. The surveying point should remain centered in the reticle.

If necessary, repeat the adjustment.

8. Replace the optical plummet reticle cover.

19.6 Distance measurement check flow chart

- Perform the procedures in the flow chart below. If error messages are displayed, please contact your SOKKIA agent. (Set parameter "EDM measurement" to "Repeat measurement mode" and set parameter "Resume function" to "off".)

► PROCEDURE Check

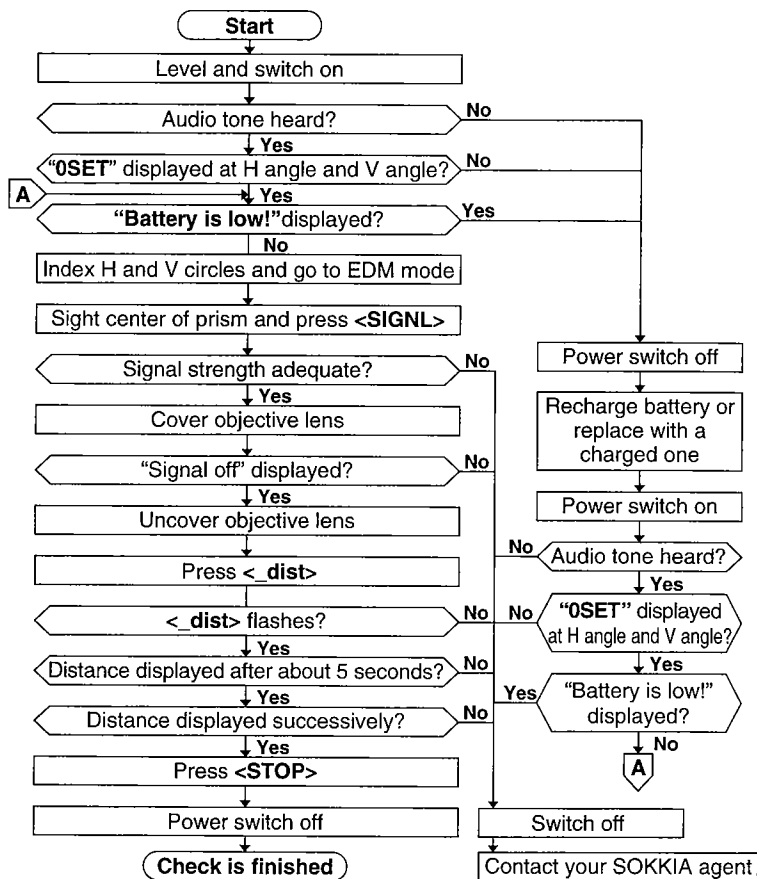

19.7 Additive distance constant

- The additive distance constant K of the SET is adjusted to 0 before delivery. However, it may change over time and so should be determined periodically and then used to correct distances measured.

The most reliable method of confirming the constant is to test the SET on an established baseline. If a baseline is not available, please perform the following procedures.

- **NOTE** Errors in setting up the instrument and sighting the target will affect the determination of the additive distance constant, therefore perform these procedures as carefully as possible.

► PROCEDURE

Check

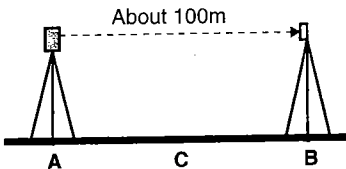

1. Select points A and B on flat ground about 100m apart, and C in the middle.

2. Set up the SET at A and the target at B.

3. Measure (fine measurement) the distance A-B 10 times.

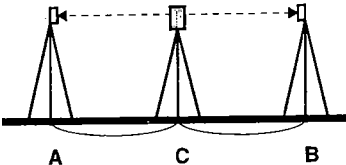

4. Shift the SET to C and measure the distance C-A and C-B 10 times each.

5. Calculate the averages of AB, CA and CB.

6. Compute the additive distance K using the formula:

$$K = AB - (CA + CB).$$

7. Obtain the K value several times.

If all K values are greater than $\pm 3\text{mm}$, please contact your SOKKIA agent.

► **NOTE** Ensure that the target height is the same as the instrument height. If the ground is not flat, use an automatic level to set the correct instrument heights of all points.

Measurement options selection

- 20. CHANGING INSTRUMENT PARAMETERS 135**
- 21. CHANGING LOCATION OF FUNCTIONS FOR KEYS ... 144**
 - 21.1 Key function allocating 146
 - 21.2 Registered location recalling 151
 - ▶ **EXPLANATION** Difference between “Enter” and “Key registration” in key function allocating 152
- 22. POWER SUPPLIES 153**
- 23. REFLECTING PRISMS AND ACCESSORIES ... 156**



20. CHANGING INSTRUMENT PARAMETERS

- The instrument parameter settings can be changed by key operations to match the required measurement.
- The selected options are stored in the memory until they are changed.

Parameter	Options	
EDM measurement (Distance measurement mode)	1* 2 3	0*: Repeat and fine 1: Single and fine 2 to 9: Average of 2 to 9 meas. Fine and single Coarse and single
Prism constant correction value	-30mm* (-99 to 0mm, in 1mm steps)	
Distance unit	1* 2	meters feet
C+R correction	1* 2	No correction Yes (K = 0.142)
Aiming beep (Audio for return signal)	1* 2	Audio tone No audio tone
Meas. mode default (Distance mode)	1* 2 3	Slope distance Horizontal distance Height difference
Angle unit	1* 2 3	degree gon mil
V angle format	1* 2 3	Zenith angle (Zenith 0°) Vertical angle (Horizontal 0°) Vertical angle (Horizontal ±90°)
V circle indexing	1* 2	Transit telescope Observe face left, face right sightings
H circle indexing	1* 2	Rotate upper part 0° at power on
Tilt correction	1* 2 3	Horizontal and Vertical angle Yes Vertical angle Yes No correction
Reticle illumination	1* 2	Bright Dim
Backlight control (Auto illumination cut-off)	1* 2	Illumination on/off using key Illumination auto off after 30 seconds

Parameter	Options	
Auto power cut-off	1* 2	Auto power cut-off after 30 minutes Switch on/off by key
Baud rate	1* 2	1200 baud 9600 baud
Resume function	1* 2	On Off
Coordinate format	1* 2	N, E, Z E, N, Z
Angle resolution	1* 2	1" (0.2mgon / 0.005mil) 5" (1mgon / 0.02mil)
Temperature and pressure unit	1* 2 3	°C, hPa °C, mmHg °F, hPa / °F, mmHg / °F, inchHg
Point number increment	1*	(001 to 999, in 1 steps)
Xon / Xoff	1* 2	Yes No
Checksum	1 2*	Yes No

*: Factory setting

► PROCEDURE From Basic mode to Setting mode

In Basic mode

Press function 13
keys to select - 30
operation **■**2
EDM THEO S-O CONF

<CONF>

Setting mode

1. Configuration
2. Tilt correction
3. Key select
■1**■** **■**2**■** **■**3**■** Exit

<1>

In Basic mode

1. Press <CONF> for Setting mode.

2. Press <1> for Parameter setting mode.

The first parameter is displayed.

3. Select the required options by the following key operations.

- To next parameter: <↓>
- To previous parameter: <↑>
- Change options: <Edit>
- To Setting mode: <Exit>
- To Basic mode: <ESC>

► PROCEDURE Edit the parameter

1. Select the parameter to be edited with <↓> or <↑> and press <Edit>.

2. Edit the parameter.

EDM measurement (Distance measurement mode)

```

1. fine    average
2. fine    single
3. coarse  single
■1■  ■2■  ■3■  Exit
  
```

<1>

```

the number of times
                0
■↑■  ■↓■                Enter
  
```

<1>: Fine average (measure selected times and display its average)

Set "the Number of times" using <↑> (count up) and <↓>(count down), and press <Enter>.

0 Repeat

1 Measure 1 time and display the result.

2 to 9 .. Measure selected times and display its average.

<2>: Fine and single

- <3>: Coarse and single
- <Exit>: Retain the previously selected option.

Prism constant

PC = - 30 mm

↑
 ↓
 →
 Enter

Set "the prism constant" using <↑> (count up) and <↓> (count down), and press <Enter>. (To move the column, press <→>.)

- The input range is -99 to 0 mm (least input is 1 mm).
- Each reflecting prism type has a different prism constant value. Here, we will set the constant correction value for the reflecting prism being used.
- The prism constant correction values for reflecting prisms made by SOKKIA are as follows:

AP01S + AP01

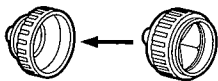

Correction value = -30

AP01



Correction value = -40

CP01



Correction value = 0

Distance unit

1. meter

2. feet

1 2
 Exit

- <1>: meters
- <2>: feet
- <Exit>: Retain the previously selected option.

C+R correction

1. No

2. Yes

1 2
 Exit

- <1>: No correction
- <2>: Yes (K=0.142)
- <Exit>: Retain the previously selected option.

- About C & R correction, refer to "Appendix 3: C&R CORRECTION"

Audio for return signal

1. Yes
2. No
<input type="checkbox"/> 1 <input type="checkbox"/> 2 <input type="checkbox"/> Exit

- <1>: Audio tone
 <2>: No Audio tone
 <Exit>: Retain the previously selected option.

Distance mode (select distance mode at power on when the resume function is off)

1. Sdist
2. Hdist
3. Vdist
<input type="checkbox"/> 1 <input type="checkbox"/> 2 <input type="checkbox"/> 3 <input type="checkbox"/> Exit

- <1>: Slope distance
 <2>: Horizontal distance
 <3>: Height difference
 <Exit>: Retain the previously selected option.

Angle unit

1. degree
2. gon
3. mil
<input type="checkbox"/> 1 <input type="checkbox"/> 2 <input type="checkbox"/> 3 <input type="checkbox"/> Exit

- <1>: degree
 <2>: gon
 <3>: mil
 <Exit>: Retain the previously selected option.

V angle format

1. Zenith
2. H. = 0...360
3. H. = +/- 90
<input type="checkbox"/> 1 <input type="checkbox"/> 2 <input type="checkbox"/> 3 <input type="checkbox"/> Exit

- <1>: Zenith 0°
 <2>: Horizontal 0°
 <3>: Horizontal +/- 90°
 <Exit>: Retain the previously selected option.

• Zenith 0°

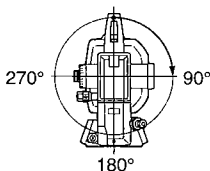

• Horizontal 0°

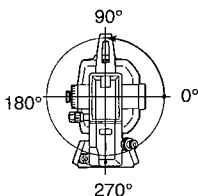

• Horizontal ±90°

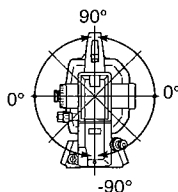

V circle indexing

1. Auto			
2. Manual			
■1■	■2■		Exit

- <1>: Transit telescope
 <2>: F.L./F.R.Sighting
 <Exit>: Retain the previously selected option.

- Refer to "Appendix 3: C&R CORRECTION" to index by face left, face right sighting.

H circle indexing

1. Auto			
2. Manual			
■1■	■2■		Exit

- <1>: Rotate upper part
 <2>: 0° at power on
 <Exit>: Retain the previously selected option.

Tilt correction

1. Yes (H, V)			
2. Yes (V)			
3. No			
■1■	■2■	■3■	Exit

- <1>: H & V angle Yes
 <2>: V angle Yes
 <3>: No
 <Exit>: Retain the previously selected option.

Reticle illumination

1. Bright			
2. Dim			
■1■	■2■		Exit

- <1>: Bright
 <2>: Dim
 <Exit>: Retain the previously selected option.

Auto illumination cut-off

1. Key on/off
2. 30sec timeout

■1■ ■2■ Exit

- <1>: On/Off using key
<2>: Auto off after 30 seconds
<Exit>: Retain the previously selected option.

Auto power cut-off

1. 30min timeout
2. Continuous

■1■ ■2■ Exit

- <1>: Auto power off after 30 minutes
<2>: On/Off using key
<Exit>: Retain the previously selected option.

Baud rate

1. 1200 baud
2. 9600 baud

■1■ ■2■ Exit

- <1>: 1200 baud
<2>: 9600 baud
<Exit>: Retain the previously selected option.

Resume function

1. Yes
2. No

■1■ ■2■ Exit

- <1>: Resume function ON
<2>: Resume function OFF
<Exit>: Retain the previously selected option.

Coordinate format

1. N, E, Z
2. E, N, Z

■1■ ■2■ Exit

- <1>: N, E, Z
<2>: E, N, Z
<Exit>: Retain the previously selected option.

Angle resolution

1. 1° / 0.02mgon
 2. 5° / 1mgon
 ■1■ ■2■ Exit

<1>: 1" / 0.02mgon
 <2>: 5" / 1mgon
 <Exit>: Retain the previously selected option.

T&P unit

1. °C hPa
 2. °C mmHg
 3. Next
 ■1■ ■2■ ■3■ Exit

<1>: °C, hPa
 <2>: °C, mmHg
 <3>: Next
 <1>: °F, hPa
 <2>: °F, mmHg
 <3>: °F, inchHg
 <Exit>: Retain the previously selected option.

<3>

1. °F hPa
 2. °F mmHg
 3. °F inchHg
 ■1■ ■2■ ■3■ Exit

Point number increment

increment = 001
 ■↑■ ■↓■ ■→■ Enter

Set "Point number increment" using <↑> (count up) and <↓> (count down), and press <Enter>. (To move the column, press <→>.)

- The input range is 0 to 999 mm (least input is 1).

X on / X off

1. Yes
2. No
<input type="checkbox"/> 1 <input type="checkbox"/> 2 <input type="checkbox"/> Exit

<1>: Yes

<2>: No

<Exit>: Retain the previously selected option.

Checksum

1. Yes
2. No
<input type="checkbox"/> 1 <input type="checkbox"/> 2 <input type="checkbox"/> Exit

<1>: Yes

<2>: No

<Exit>: Retain the previously selected option.

21. CHANGING LOCATION OF FUNCTIONS FOR KEYS

- The SET allows you to change locations of the functions for each key (except <ESC>). You can arrange the keyboard according to your requirements in order to save key strokes and to avoid mistakes. You will get the most efficiency by customizing function locations for your own applications.

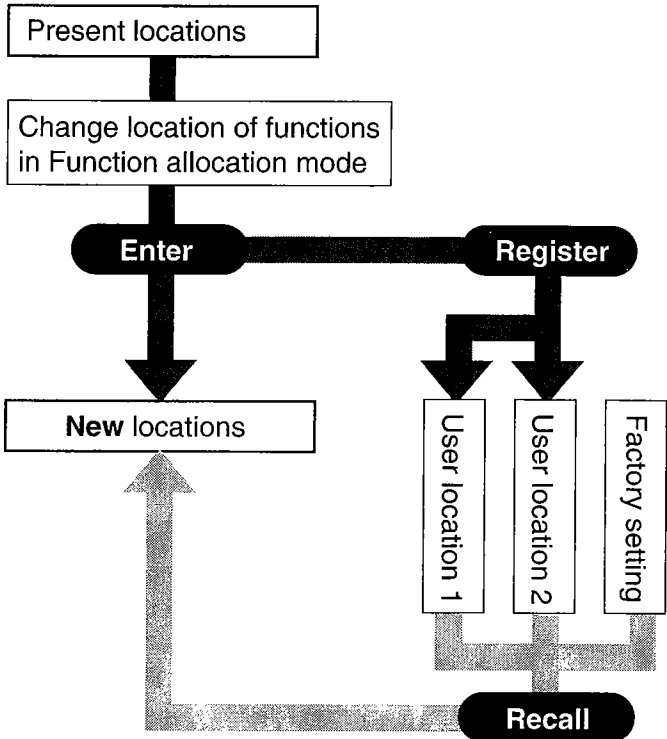

- Difference between "Enter" and "Register" ► **EXPLANATION**
Difference between "Enter" and "Key registration" in key function allocating

- The factory settings are shown below. "User location 2" settings can be changed. If changed, the previous settings will be erased and cannot be recalled.

Factory setting

EDM mode

Sdist	0
< Fine average >	-30
	■3
Sdist	▲SHV THEO →P2
PPM M/TRK SIGNAL	→P3
REM MLM OFFS	→P1

User location 2

EDM mode

Sdist	0
< Fine average >	-30
	■3
Sdist	REC COORD →P2
▲SHV M/TRK MEM	→P3
REM MLM RESEC	→P1

Theodolite mode

	0
ZA	112° 21' 20° -30
HAR	350° 38' 10° ■3
Sdist	EDM ILLUM →P2
0SET HOLD Tilt	→P3
REP ZA/% R/L	→P1

Theodolite mode

	0
ZA	112° 21' 20° -30
HAR	350° 38' 10° ■3
BSang	0SET HOLD →P2
PPM SIGNAL Tilt	→P3
REP ZA/% R/L	→P1

Setting-out mode

	0
S-O / COORDS	-30
	■3
SO_3D S-O_P S-O_D	→P2
Stn_P Ht. COORD	→P3
MEM RESEC ▲SHV	→P1

Setting-out mode

	0
S-O / COORDS	-30
	3
S-O_P SO_HA SO_Hd	→P2
Stn_P Ht. M/TRK	→P3
S-O_D RESEC ▲SHV	→P1

21.1 Key function allocating

- Any functions mentioned below can be allocated in any page of any mode. After storing the locations, the locations are stored permanently until they are changed again. 2 locations can be registered at the internal memory. The registered location can be renewed.

► **NOTE** The previously-stored locations of functions are cleared after changing or registering the new locations.

- The following functions can be allocated in each mode (THEO, EDM and S-O).

► **NOTE** The functions marked with * are not allocated in the default setting.

General

- <THEO> : Transfer to THEO mode
- <EDM> : Transfer to EDM mode
- <S-O> : Transfer to S-O mode
- <CONF> : Transfer to Setting mode
- <→PX> : Go to next page
- <--->* : No function
- <ILLUM> : Display and reticle illumination ON/OFF
- <MEM> : Select job
Input/Delete/Review Measured and coordinate data and Feature code
- <Rec>* : Record Instrument station data and Measured data
- <off> : Switch the power off

For Angle measurement

- <0SET>** : Set Horizontal angle to 0 /Index V circle
- <HOLD>** : Hold H angle / Release H angle
- <Tilt>** : Display the tilt angle
- <REP>** : Transfer to Repetition mode
- <ZA/%>** : Zenith angle / Slope in % ^(*)
- <VA/%>** : Vertical angle / Slope in % ^(**)
- <R/L>** : Select Horizontal angle right / left

For Distance measurement

- <_dist>** : Measure the distance
- <▲ SHV>** : Select Distance mode
(S=Slope / H=Horizontal / V=Height)
- <PPM>** : Go to ppm setting mode
- <M / TRK>** : Repeat or single meas. / Tracking meas.
- <SIGNL>** : Return signal check
- <f / m>*** : Change meters / feet for 5 seconds
- <RCL>*** : Review the measured data in the memory

For Coordinate measurement

- <Stn_P>** : Input Instrument station coordinates
- <Ht.>** : Input Target & Instrument height
- <BSang>*** : Input Backsight station coordinates and set
Azimuth angle
- <COORD>** : Measure 3-Dimensional coordinates

^(*) : "ZA/%" is displayed when parameter "V angle format" is set to "Zenith 0".

^(**) : "ZA/%" is displayed when parameter "V angle format" is set to "Horizontal 0" or "Horizontal $\pm 90^\circ$ ".

For Advanced measurement

- <RESEC> : Go to Resection measurement mode
- <OFFS> : Start offset measurement
- <MLM> : Start Missing line measurement
- <REM> : Start Remote elevation measurement
- <S-O_D> : Input Distance setting-out data
- <S-O_P> : Input Coordinates of point to be set out
- <SO_3D> : Start 3-dimension setting-out measurement.
- <SO_Xd> : Start Distance setting-out measurement
- <SO_HA> : Start H angle setting-out measurement

► PROCEDURE Key function allocating**Basic mode**

```

Press function      13
keys to select     -30
operation          █2
EDM THEO S-O CONF
  
```

<CONF>

Setting mode

```

1. Configuration
2. Tilt correction
3. Key select
█1█ █2█ █3█ Exit
  
```

<3>

Key selection mode

```

1. define
2. recall
█1█ █2█ Exit
  
```

<1>

Function allocating mode

```

1. Distance key
2. Theodolite key
3. Settingout key
█1█ █2█ █3█ Exit
  
```

<1> or <2> or <3>

In Basic mode

1. Press <CONF> for Setting mode.
2. Press <3> for Key selection mode.
3. Press <1> for Function allocating mode.
4. Select the required mode.
 - EDM mode: <1>
 - THEO mode: <2>
 - S-O mode: <3>

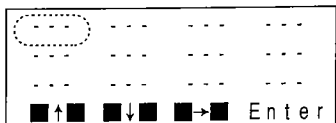

<↓> or <↑>, <→>

<Enter>

First line = First page
 Second line = Second page
 Third line = Third page

- Go to next function: <↓>
- Go to previous function: <↑>
- Go to next position: <→>

5. Display the required function.
 Repeat for the required numbers of functions.

6. Press <Enter> to enter the new location into memory.

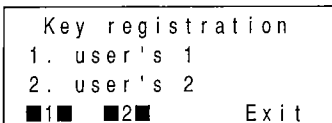

<1> or <2> or <3>

7. Register the new location to "user's 1" or "user's 2".

(The previously-registered location is cleared.)

or Exit from this mode without registering.

(Function allocating mode)

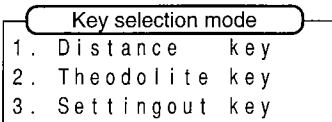

- Register to user's 1: <1>
- Register to user's 2: <2>
- Not register: <Exit>

- If there are more than 5 functions to be allocated, allocate the page-turn function in any location of each line.
- If there is no function to be allocated, allocate "-" for key.
- To Setting mode: <Exit>
- Exit from the mode: <ESC> (To Basic mode)
- Location storage period: Until next changing (Power-off possible)
- Up to 9 functions in 3 pages can be allocated

- When Coordinate functions are used, allocate related functions.
 - For 3-Dimensional coordinates measurement
 - Allocate **<Ht.>** and **<BSang>** with **<COORD>**.
 - <Ht.>** (Input Target and Instrument height)
 - <BSang>** (Set Azimuth angle) *
 - <COORD>** (Measure 3-Dimensional coordinates)
- If these are not allocated, the previously stored data is used.

21.2 Registered location recalling

- The factory setting location or the registered locations stored in the memory can be recalled.

► PROCEDURE Key function recalling

Basic mode

```

Press function 13
keys to select -30
operation      2
EDM THEO S-O CONF
  
```

In Basic mode

1. Press <CONF> for Setting mode.

<CONF>

Setting mode

```

1. Configuration
2. Tilt correction
3. Key select
■1■ ■2■ ■3■ Exit
  
```

2. Press <3> for Key selection mode.

<3>

Key selection mode

```

1. define
2. recall
■1■ ■2■ Exit
  
```

3. Press <2> for Key function recalling mode.

<2>

Key function recalling mode

```

1. user's 1
2. user's 2
3. default
■1■ ■2■ ■3■ Exit
  
```

4. Select the required location. (Key function mode)

- Recall "user's 1": <1>
- Recall "user's 2": <2>
- Recall Factory setting: <3>

- The previously-stored locations of functions are **cleared** after recalling the registered locations.
- To Setting mode: <Exit>
- To Basic mode: <ESC>

► **EXPLANATION** **Difference between “Enter” and “Key registration” in key function allocating**

- There are 2 methods for changing the locations of functions for keys. By knowing how to use “**Enter**” or “**Key registration**” properly, it will be easier to operate the SET.
 - ① <**Enter**> the new location or **register** the new location:
After **entering** the new location, the functions are displayed in the entered location until next changing.
 - ② Recall the **registered** locations:
After **registering** a location, the **registered** location can be recalled at any time.

For example, if someone **enters** another location, you can recall the location you **registered**.

22. POWER SUPPLIES

- The SET can be operated with the following combinations.

► **NOTE** Use the SET only with the combinations shown here.

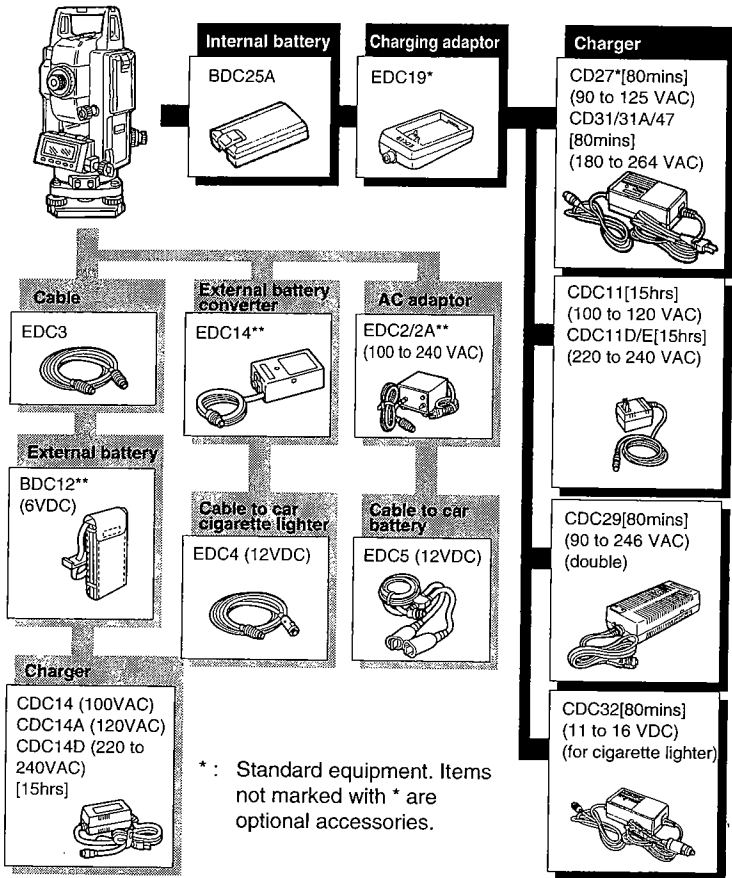

► **IMPORTANT** Accessories other than the BDC25A do not meet IPX7 specifications for water proofing.

- **NOTE** When using any external power supply (**), it is recommended that the BDC25A battery be left in place to balance the weight on the axes.

Battery BDC25A

- Battery operating life is shortened at extreme temperatures due to the battery's Ni-Cd composition.
- If the battery is discharged excessively, its life may be shortened. Store it in a charged state.
- The battery can be recharged about 300 times under ordinary use (Temperature = 20°C, Humidity = 65%).
- The storage temperature is between 0 and 40°C.
- Specifications:
 - Output voltage: 6VDC
 - Capacity: 1200mAh
 - Water resistance: conforms to IPX7 (BDC25A)
 - Size: 58 x 23 x 92mm
 - Weight: about 0.2kg

Battery charger CDC27, CDC31, CDC31A or CDC47

- The battery charger becomes warm while charging. This is normal.
- How to charge: Connect the charger to the power supply, connect the adaptor to the battery charger and mount the battery in the adaptor.
Then;
 - the charging light flashes during charging and lights steadily when charging is finished. (CDC27/CDC31/ CDC47)
 - the charging lamp lights on during charging and it flashes when the charging is finished. (CDC31A)
- The charging temperature is between 10 and 40°C.
- Charge the battery until the light remains on.

- Specifications:
 - Input: CDC27: 90 to 125V AC, 50/60Hz, 20VA
CDC31/31A/47: 180 to 264V AC, 50/60Hz, 20VA
 - Output: 7.5V DC, 1.2A
 - Charging time at 25°C: about 80 minutes (BDC25A)
 - Size: 66 x 124 x 45mm
 - Weight: CDC27: about 0.35kg
CDC31/31A/47: about 0.38kg

► **PRECAUTION** **For the use of external power supplies**

- Ensure that the car cigarette lighter has 12V DC output and that the negative terminal is grounded. Leave the engine running during use.
- Before using EDC2, set the voltage selector to the correct voltage.
- EDC14 has a breaker switch. If you short circuit the battery or the polarity is not correct, the breaker will switch off the power. When the breaker switches off the power, remove the rubber cover and set the breaker switch so that a red mark appears.

23. REFLECTING PRISMS AND ACCESSORIES

- All SOKKIA reflecting prisms and accessories have standardized screws (5/8" x 11 thread) for ease of use.

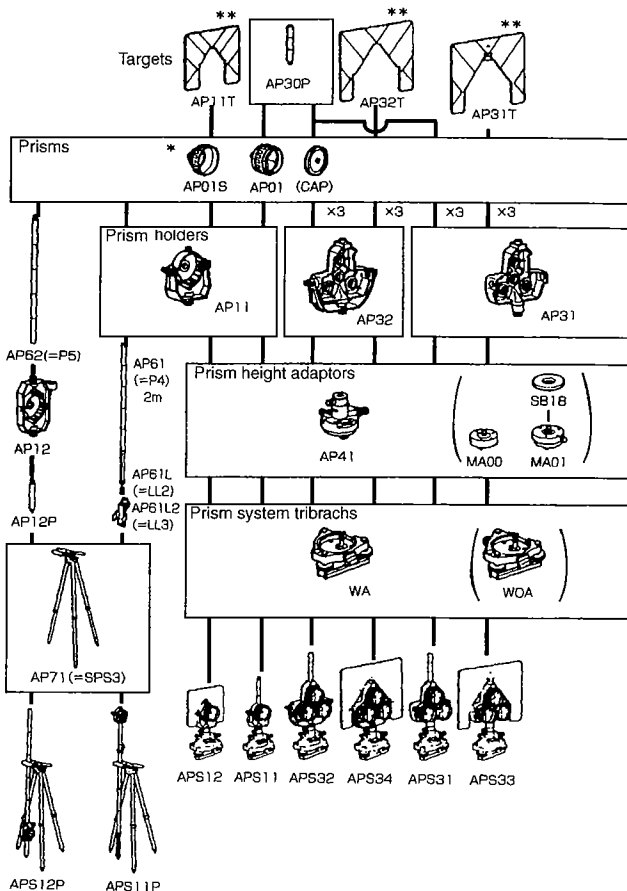

- All the above equipment is optional.
- *: To change the stored prism constant value, see chapter 20.
- ** : Fluorescent target paint finishing allows clearer sighting in adverse observing conditions.

► **PRECAUTION** For use of reflecting prisms

- Carefully face the reflecting prism towards the instrument and sight the prism target center accurately.
- To use the triple prism assembly AP31 or AP32 as a single prism (e.g. for short distances), mount the single prism AP01 in the center hole of the prism holder.

► **PRECAUTION** For use of the instrument height adaptor AP41

- Check the plate level of the AP41 as described in “**19.1 Plate level**”.
- Check that the optical plummet of the AP41 sights the same point as that of the SET, referring to “**19.5 Optical plummet**”.
- Check that “236” (the height of the SET in mm) is displayed in the window of the instrument height adaptor AP41.

► **PROCEDURE** Adjustment for the height of the AP41

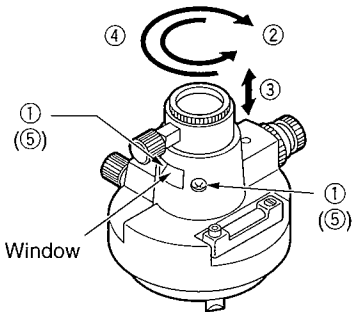

- ① Loosen the 2 fixing screws.
- ② Turn the center part counterclockwise to unlock it.
- ③ Move it up or down until “236” appears in the window.
- ④ Turn the center part clockwise to lock it.
- ⑤ Tighten the fixing screws.

► **PRECAUTION** For use of tribrach

- Use the plate level on the AP41 to adjust the tribrach circular level as described in “**19.2 Circular level**”.



Appendices

Appendix 1: Manually indexing the vertical circle by face left, face right measurements ...	161
Appendix 2: For distance measurement of the highest accuracy	162
Appendix 3: Earth-curvature and refraction correction	164
Appendix 4: Standard accessories	165
Appendix 5: Optional accessories	166
STANDARD EQUIPMENT	168
MAINTENANCE	169
SPECIFICATIONS	170
ATMOSPHERIC CORRECTION CHART	174
REGULATIONS	175



Appendix 1: Manually indexing the vertical circle by face left, face right measurements

- Like all theodolites, the SET will have a small vertical index error. For angle measurement of the highest accuracy, the vertical index error can be removed as follows:
- Set Parameter "V circle indexing" to "Manual". See chapter 20.

► PROCEDURE Manually indexing the vertical circle

ZA	V 1	
HAR	60' 00"	2 

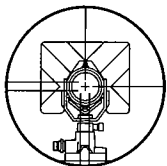

1. Level the SET.

"V1" is displayed.

2. In face left (V1), accurately sight a clear target at a horizontal distance of about 30m.

<OSET>

ZA	V 2	
HAR	60° 00' 00"	 2

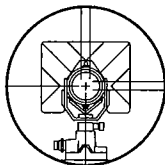

3. Press <OSET>.

"V2" is displayed.

4. Loosen the horizontal clamp and rotate the upper part of the SET through 180°. In face right (V2), accurately sight the same target.

5. Press <OSET>.

The vertical circle has been indexed.

<OSET>

ZA	89° 10' 40"	
HAR	240° 00' 00"	 2

- If the power is switched off, the vertical circle should be indexed again.

Appendix 2: For distance measurement of the highest accuracy

- **Atmospheric correction**

The SET uses a beam of infrared light to measure the distance. The velocity of this light in the atmosphere varies according to the temperature and pressure. The distance will be changed by 1ppm by:

- a variation in temperature of 1°C
- a variation in pressure of 3.6hPa

(A 1ppm change means a 1mm difference for every 1km of measured distance.)

To obtain distance measurement of the highest accuracy, the temperature and pressure must be carefully measured by accurate equipment.

- The ppm correction should be applied when the calculated ppm value is over ± 5 ppm or if the slope distance is more than 200m.
- **Average temperature and pressure between 2 points in different atmospheric conditions**

In flat terrain: Measure the temperature and pressure at the midpoint of the line as there is little variation in the values.

In mountainous terrain: Midpoint values should be used. If those values cannot be measured, measure temperature and pressure at the instrument and target stations, then calculate the average values.

$$\text{Average temperature} = (t_1 + t_2) / 2$$

$$\text{Average pressure} = (p_1 + p_2) / 2$$

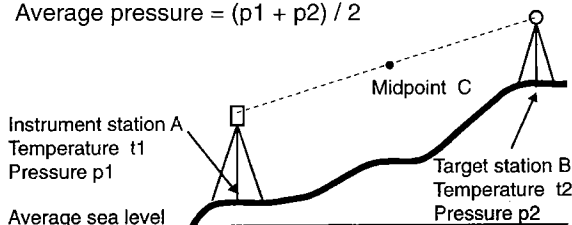

• **Influence of relative humidity**

The influence of humidity is very small. It is mainly of importance in very hot and humid conditions.

Correction factor B (ppm)

$$= \frac{0.045 \times e \text{ (hPa)}}{1 + 0.003661 \times t \text{ (}^\circ\text{C)}}$$

e: Partial water vapour pressure

t: Temperature

If you take the influence of relative humidity into account, please set the correction factor (ppm) by the following method.

- ① Input the temperature and pressure values. The correction factor A is calculated and displayed at the end of 1st line of display. Measure the distance D.
- ② Measure the relative humidity and read the correction factor B from above formula. For pressure between 500hPa and 1400hPa, a difference of less than 0.1ppm will be present.
- ③ Calculate D' by using the following formula.

$$D' = \frac{1 + (A+B) \times 10^{-6}}{1 + A \times 10^{-6}} \times D \text{ (m)}$$

e.g. Temperature: 30°C, Pressure: 1020hPa,

Relative humidity: 80%

Measure distance corrected by only the correction factor A:
2000m

A=12 (the end of first line of display), B=1.4

$$D' = \frac{1 + (12 + 1.4) \times 10^{-6} \times 2000}{1 + 12 \times 10^{-6}} = 2000.0028 \text{ (m)}$$

Appendix 3: Earth-curvature and refraction correction

- When measuring the horizontal distance and height difference, the earth-curvature and refraction correction can be selected by the parameter "C + R correction".
- Difference between "no correction" and "applied correction"**

(No correction)

Horizontal distance: $H = S \times \sin Z$

Height difference: $V = S \times \cos Z$

(Applied correction)

Horizontal distance: $H' = S \times \sin Z - \frac{1-K/2}{R} \times S^2 \times \sin Z \times \cos Z$

Height difference: $V = S \times \cos Z + \frac{1-K}{2R} \times S^2 \times \sin^2 Z$

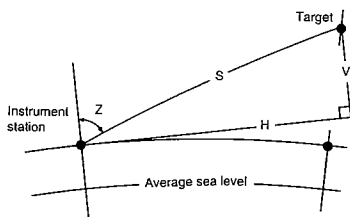

S: Slope distance

(atmospheric corrected value)

Z: Vertical angle (0° at zenith)

K: Atmospheric refraction constant
(0.142)

R: Radius of the earth
(6.372×10^6 m)

e.g.: Correction value at $Z=70^\circ$ ($K=0.142$)

S distance	200m	500m	1000m	1500m
$H' - H$	-0.002m	-0.012m	-0.047m	-0.105m
$V' - V$	0.002m	0.015m	0.059m	0.134m

- **NOTE** The horizontal distance is the distance measured at the height of the surveying point above sea level. If required, reduce this distance to the average sea level and apply the local projection correction.

Appendix 4: Standard accessories

• Plumb bob

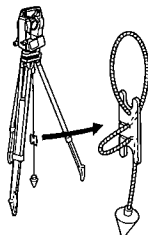

- If the weather is calm, or for initial tripod centering, the plumb bob can be used for centering. To use, unwind the plumb bob and attach it to the hook inside the centering screw. Use the cord grip piece to adjust the cord length.

• Tubular compass CP7

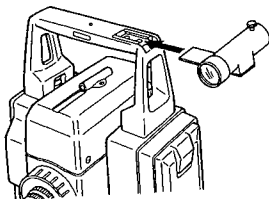

- To mount the CP7, slide it into the tubular compass slot. To use, loosen the clamping screw to free the compass needle. Turn the instrument in the face left position until the compass needle bisects the index lines. The telescope is now aligned with magnetic north. After use, tighten the clamp and remove the compass from the slot. Replace it in the specified position in the carrying case.

► **NOTE** Magnetism and metal will influence the tubular compass, making it incapable of projecting true magnetic north. Do not use the magnetic north indicated by this compass for base line surveying.

• Handle

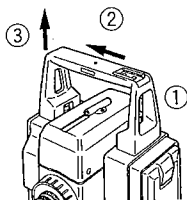

- The carrying handle can be removed from the instrument as follows:
 - ① Unscrew the handle securing screw
 - ② Slide the handle to the side
 - ③ Remove the handle

Appendix 5: Optional accessories

- **Diagonal eyepiece DE17A**

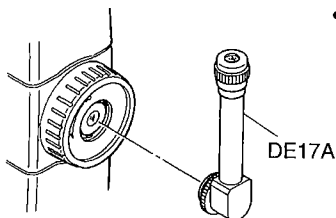

- The diagonal eyepiece is convenient for near-vertical observations and in places where space around the instrument is limited. Remove the handle and the telescope eyepiece by unscrewing the mounting ring, and screw in the diagonal eyepiece.

► **IMPORTANT** When the diagonal eyepiece is attached, SET W's capacity of water resisting is reduced.

- **Solar filter OF1/OF1A**

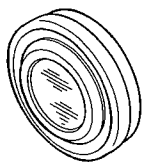

DF1

- For observations to the sun, and where glare is present. The OF1 and OF1A (flip-up type) filters are mounted on the objective lens.

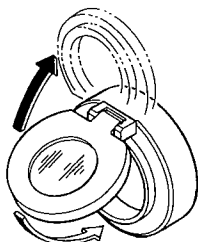

DF1A

- **Electronic field book SDR series**

- The SDR series collects and stores slope distance and, vertical and horizontal angle data from the SET. Calculations can be performed on the data so that the measurements can be verified in the field. The stored data can be transmitted to a data processing system.

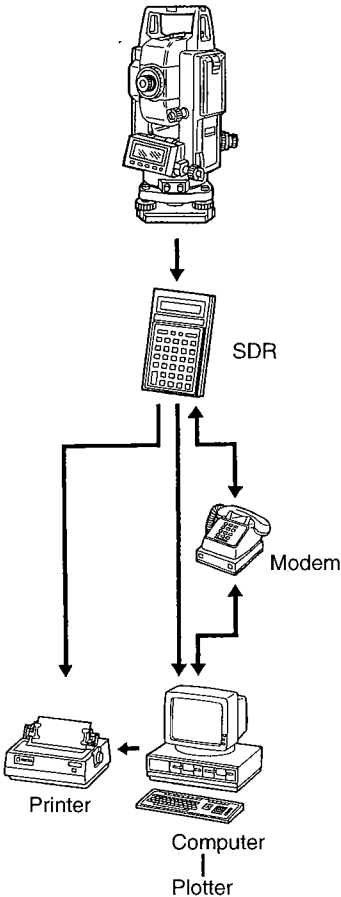

► **IMPORTANT** When the SET W is connected with the SDR series, its capacity of water resisting is reduced.

STANDARD EQUIPMENT

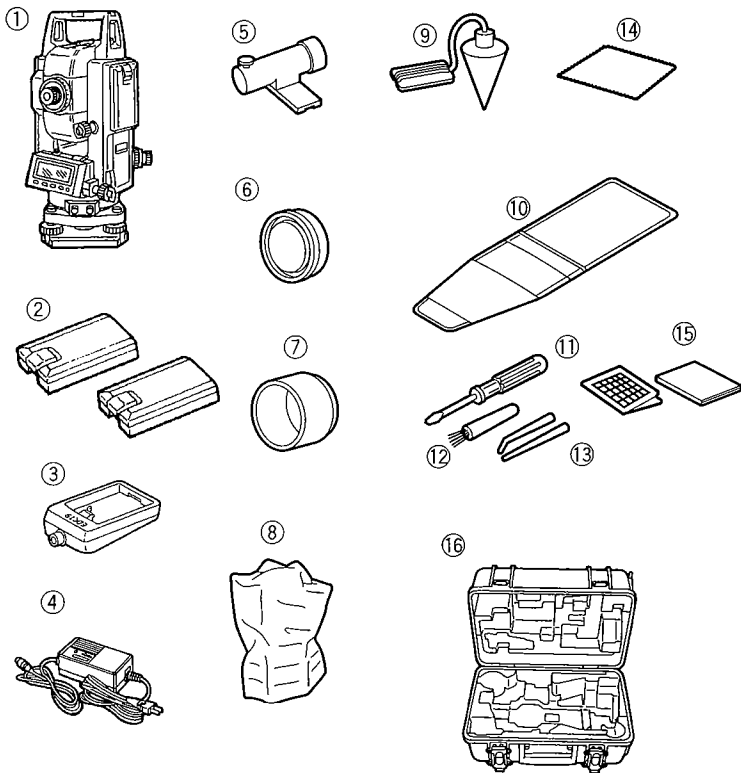

- ① SET5F/5FS/5W/5WS 1
- ② Internal battery, BDC25A 1
- ③ Battery charging adaptor, EDC19 1
- ④ Battery charger, CDC27/31/31A/47 1
- ⑤ Tubular compass, CP7 1
- ⑥ Lens cap 1
- ⑦ Lens hood 1
- ⑧ Vinyl cover 1

- ⑨ Plumb bob 1
- ⑩ Tool pouch 1
- ⑪ Screwdriver 1
- ⑫ Lens brush 1
- ⑬ Adjusting pin 1
- ⑭ Cleaning cloth 1
- ⑮ Operator's manual 1
Atmospheric correction chart .. 1
- ⑯ Carrying case (SC129) 1

MAINTENANCE

1. Make sure that the inside of the carrying case and the instrument are dry before closing the case. If moisture is trapped inside the case, it may cause the instrument to rust.
2. Always clean the instrument before returning it to the case. The lens requires special care. Dust it off with the lens brush first, to remove minute particles. Then, after providing a little condensation by breathing on the lens, wipe it with a soft clean cloth or lens tissue.
3. Do not wipe the displays and keyboard or carrying case with an organic solvent.
4. Store the SET in a dry room where the temperature remains fairly constant.
5. Check the tripod for loose fit and loose screws.
6. If any trouble is found on the rotatable portion, screws (9, 11, 13, 18, 19, 24 and 25) or optical parts (e.g. lens), contact your SOKKIA agent.
7. When the instrument is not used for a long time, check it at least once every 3 months.
8. When removing the SET from the carrying case, never pull it out by force. The empty carrying case should then be closed to protect it from moisture.
9. Check the SET for proper adjustment periodically to maintain the instrument accuracy.

SPECIFICATIONS

Telescope

Length:	165mm
Aperture:	45mm
Magnification:	30 x
Image:	Erect
Resolving power:	3"
Field of view:	1°30' (26m / 1000m)
Minimum focus:	1.3m
Reticle illumination:	Bright or dim settings (Selectable with parameter)

Angle measurement

Horizontal and vertical circles type:	Incremental with 0 index
Angle units:	Degree / gon / mil (Selectable with parameter)
Display range:	
Horizontal angle:	-3599° 59' 59" to 3599° 59' 59"
Vertical angle:	0°0'0" to 359° 59' 59"
Minimum display:	1" (0.2mgon / 0.005mil) / 5" (1mgon / 0.02mil) (Selectable with parameter)
Accuracy:	Standard deviation of mean of measurement take in positions I and II (DIN 18723) 5" (1.5mgon / 0.02mil)
Measuring time:	Less than 0.5sec.
Automatic compensator:	Selectable ON (V & H / only V) / OFF
Type:	Liquid, 2-axis tilt sensor
Minimum display:	Same as the angle display
Range of compensation:	±3'
Measuring mode:	
Horizontal angle:	Right / Left / Repetition / Hold (Selectable with keyboard)
Vertical angle:	Zenith 0 / Horizontal 0 / Horizontal ±90° (Selectable with parameter) Slope in % (Selectable with keyboard)

Distance measurement

Measuring range:	(Slight haze, visibility about 20km, sunny periods, weak scintillation) Compact prism CP01: 1.3 to 700m Standard prism AP x1: 1.3 to 1200m Standard prism AP x3: 1.3 to 1600m
Minimum display:	Fine measurement: 1mm Coarse measurement: 1mm Tracking measurement: 10mm
Maximum slope distance:	9999.999m
Distance unit:	meters / feet (Selectable with parameter) (Changeable for 5 seconds with keyboard)
Accuracy:	$\pm(3 + 2\text{ppm} \times D)\text{mm}$ (unit: mm, D: Measured distance, Fine measurement)
Measurement mode:	Fine & repeat measurement/ Fine & single measurement/ Fine & average measurement/ Coarse & single measurement (Selectable with parameter) Tracking measurement (Selectable with keyboard)
Measuring time:	(When "C + R correction" is not being applied.)

	Fine	Coarse	Tracking
Slope distance	4.7s + every 3.2s	1.7s	1.4s + every 0.3s
Horizontal distance Height difference	4.7s + every 3.3s	1.9s	1.5s + every 0.3s
Coordinates	5.1s + every 3.3s	2.4s	1.7s + every 0.7s
REM	0.7s + every 0.5s		
Horizontal distance between 2 points	5.8s + every 3.3s	2.9s	2.8s + every 0.7s

Signal source: Infrared LED
 Light intensity control: Automatic
 Atmospheric correction:
 Temperature input range: -30 to 60°C (in 1°C steps) /
 -22 to 140°F (in 1°F steps)
 Pressure input range: 500 to 1400hPa (in 1hPa steps)/
 375 to 1050mmHg (in 1mmHg steps)/
 14.8 to 41.3inchHg (in 0.1inchHg steps)
 (Selectable with parameter)
 ppm input range: -499 to 499ppm (in 1ppm steps)
 Prism constant correction: -99 to 0mm (in 1mm steps)
 Earth-curvature and refraction correction: ON / OFF (Selectable with parameter)

Power supply

Power source: Ni-Cd rechargeable battery, BDC25A (6VDC)
 Working duration at 25°C Distance & Angle measurement:
 (Fine & single measurement,
 measurement interval = every 30 secs)
 BDC25A: About 5 hours (About 600 points)
 Optional battery BDC12: About 25 hours
 (About 3000 points)
 Angle measurement only:
 BDC25A: About 9 hours
 BDC12: About 45 hours
 Water resistance: BDC25A: Conforms to IPX7
 Charging time: CDC27 / 31 / 31A / 47: About 80 minutes
 CDC11 / 11D / 11E: About 15 hours

General

Water resistance:	Conforms to IPX7 (SET5W/SET5WS)
Display:	2 LCD dot matrix displays on each face 20 characters x 4 lines
Keyboard:	5 softkeys Allocating functions for keys and register locations are available
Sensitivity of levels:	Plate level: 40" / 2mm Circular level: 10' / 2mm
Optical plummet:	Image: Erect Magnification: 3x Minimum focus: 0.5m
Horizontal and vertical fine motion screw:	1-speed motion
Self-diagnostic function:	Provided
Power saving auto cut off:	30 minutes after operation / On / off with key (Selectable with parameter)
Data recording:	3000 point data can be stored in memory
Data output:	Asynchronous serial, RS-232C compatible
Operating temperature:	-20 to 50°C
Instrument height:	236mm (9.3inch) from tribrach bottom
Size:	150(W) x 165(D) x 353(H)mm (with handle and battery)
Weight:	SET5F: about 5.4kg SET5FS: about 5.5kg SET5W: about 5.6kg SET5WS: about 5.7kg (with handle and battery)

ATMOSPHERIC CORRECTION CHART

- This chart shows the correction every 2ppm, while the atmospheric correction can be input to the SET for every ppm.
- To convert pressure in mmHg to hPa, divide by 0.75.
To convert pressure in inchHg to hPa, multiply by 33.87.
$$\text{hPa} = \text{mmHg} / 0.75 = 33.87 \times \text{inchHg}$$
- To convert temperature in °F to °C, compute using the following formula:
$$^{\circ}\text{C} = 0.56 \times (^{\circ}\text{F} - 32)$$

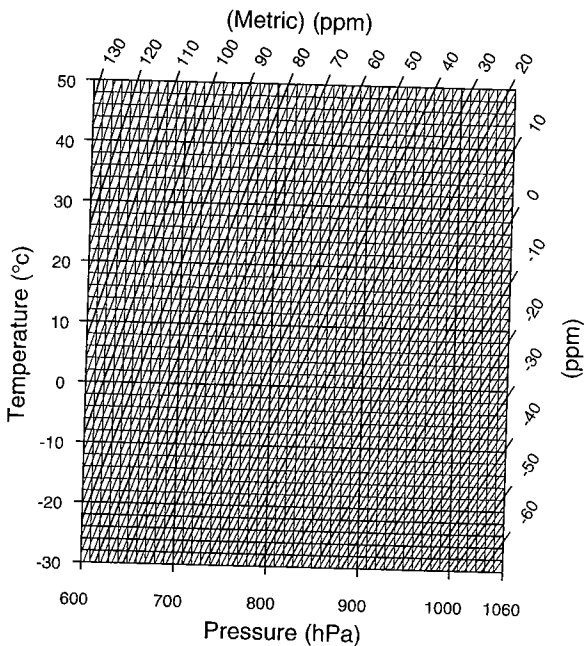

REGULATIONS

Radio Frequency Interference

WARNING: Changes or modifications to this unit not expressly approved by the party responsible for compliance could void the user's authority to operate the equipment.

NOTE: This equipment has been tested and found to comply with the limits for a Class A digital device pursuant to Part 15 of the FCC Rules. These limits are designed to provide reasonable protection against harmful interference when the equipment is operated in a commercial environment. This equipment generates, uses, and can radiate radio frequency energy and, if not installed and used in accordance with the instruction manual, may cause harmful interference to radio communications. Operation of this equipment in a residential area is likely to cause harmful interference in which case the user will be required to correct the interference at his own expense.

Notice for Canada

This Class A digital apparatus meets all requirements of Canadian Interference-Causing Equipment Regulations. Cet appareil numérique de la Class A respecte toutes les exigences du Règlement sur le matériel brouilleur du Canada.

CE Conformity Declaration

CE Declaration of Conformity

in accordance with EMC Directive 89/336/EEC of the European Community

We herewith declare that the undermentioned instrument, in view of its design and type of construction, fully complies with the relevant basic radio interference requirements of the EMC Directive.

Should the instrument be modified without agreement, this declaration becomes invalid.

Instrument Description: Total Station (Surveying Instrument)

Model Name : SETSW

Relevant EC Directive: EMC Directive (89/336/EEC)
Version: 91/263/EEC, 92/31/EEC, 93/68/EEC

Applied
Harmonized Standard: EMI EN50081-1 1993
EN5022 1994 s Class B
EMS : EN50082-2 1995
EN50140 1994
EN50141 1994
EN61000-4-2 1995
EN61000-4-2 1995

Date: 2/1/27
Firm: SOKKIA B.V.
Address: Industrieterrein De Vaart, Dambuisweg 1, NL-1332 EA Almere

SOKKIA B.V.
Industrieterrein De Vaart
Dambuisweg 1
NL-1332 EA Almere

Representative's Signature:

Name of Representative : Stephen Blakita
Representative's position : European vice President

CE Conformity Declaration

in accordance with EMC Directive 89/336/EEC of the European Community

We herewith declare that the undermentioned instrument, in view of its design and type of construction, fully complies with the relevant basic radio interference requirements of the EMC Directive.

Should the instrument be modified without agreement, this declaration becomes invalid.

Instrument Description: Total Station (Surveying Instrument)

Model Name : SETSIF, SETSIFS

Relevant EC Directive: EMC Directive (89/336/EEC)
Version: 91/263/EEC, 92/31/EEC, 93/68/EEC

Applied
Harmonized Standard: EMI EN50081-1 1993
EMS EN50082-2 1995

Date: 1.6.1996
Firm: SOKKIA B.V.
Address: Industrieterrein De Vaart, Dambuisweg 1, NL-1332 EA Almere

SOKKIA B.V.
Industrieterrein De Vaart
Dambuisweg 1
NL-1332 EA Almere

Representative's Signature:

Name of Representative : Stephen Blakita
Representative's position : European vice President

CE Conformity Declaration
in accordance with EMC Directive 89/368/EEC of the European Community

We herewith declare that the undermentioned instrument, in view of its design and type of construction, fully complies with the relevant basic radio interference requirements of the EMC Directive.
Should the instrument be modified without agreement, this declaration becomes invalid.

Instrument Description: Power Supply (Battery Charger)

Model Name : CDC31

Relevant EC Directive: EMC Directive (89/368/EEC)
Version: 91/269/EEC, 92/31/EEC, 93/68/EEC

Applied
Harmonized Standard: EN50081-1 1997 , and EN50082-2 1995

Date: Dec. 98
Firm: SOKKIA B.V.
Address: Industrieterrein 'De Vaan', Damschloeveg 1, NL-1132 EA Almere

Representative's Signature



Name of Representative : Stephen Blauke
Representative's position : European vice President

MEMO

A series of horizontal dashed lines for writing, spanning the width of the page.

